

LORO-X DRAINJET® Siphonic parapet drains without roof penetration

made of stainless steel, according to DIN EN 1253

The complete system for new and reconstructed buildings with clamping and bonding flange, for bituminous and plastic roofing sheets. Complete system consisting of drain, pipes, fittings, sealing elements and clamps for installing the system in a fast and safe way.

- as main drainage
- as emergency drainage
- in DN 50 and DN 70

With LORO DRAINJET®-siphonic parapet drainage systems the roof or the heat insulation will not be penetrated.

The capacity of each complete system can clearly be proved with the help of the LORO-X data sheets, so that planning the drainage is uncomplicated and requires little time. The pressure-resistant LORO-X system of steel drainage pipes will ensure safe operations and easy installation on the construction site based on the reliable LORO-X push-fit socket.

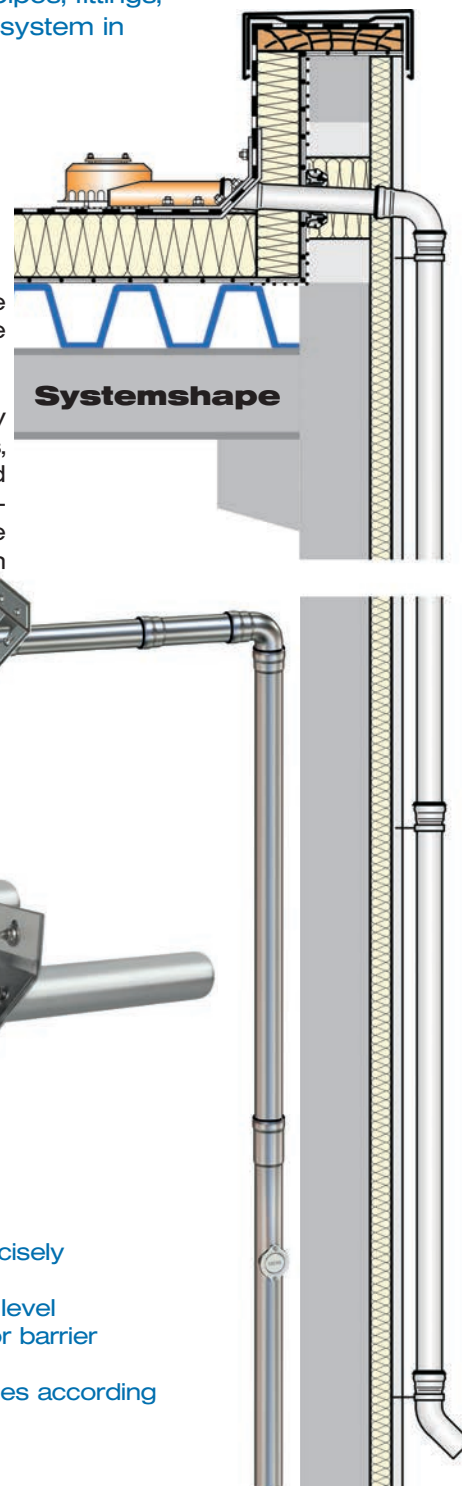

Advantages:

- no penetration of the roof!
- no drainage pipes inside the building
- complete systems with a reliable certificate precisely to CAD design
- high drainage performance at a low roof water level
- connection with the roof covering and the vapor barrier in conformity with the standards
- pressure-resistant system of steel drainage pipes according to DIN EN standard 1123

LORO-X series 62 DRAINJET®-Parapet

without penetration into the roof

The specification in this Current

The LORO-X DRAINJET-Parapet drainage as a spout with gravity flow or in a complete system with siphonic flow is specified for planning, manufacture and execution as a roof drainage system with the following means, which are also available in the LORO-X Online Service.

The LORO-X internal and field service team looks forward to a personal discussion.

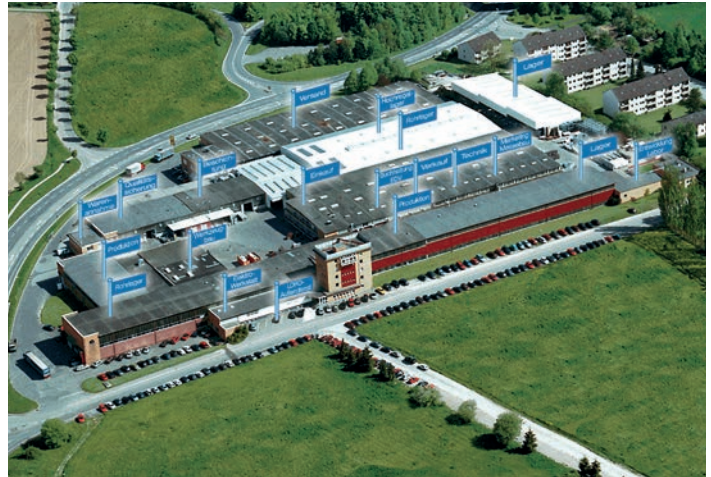

Optimisation qualities	3
Overview	4 -5
Description	6 - 9
Applications	10 - 11
Dimensioning	12 - 13
Dimensions and weights	14 - 19
LORO-X data sheets	20 - 37
LORO-X online service	38 - 39
Contact	40

LORO roof drainage technology and specification

The LORO-X DRAINJET-Parapet drainage is also a roof drainage system that reliably provides for optimum drainage. The optimisation qualities correspond to the optimisation of certain features, which are presented with their optimisation values on page 3.

Roof drainage that reliably provides for optimum drainage necessitates a good specification and thus good communication between everyone involved in the task fields of research, development, planning, design, manufacturing, works, assembly, installation, distribution, consulting, testing, administration, patents and standards - with the support of the LORO internal and field service team.

When tendering the LORO drainage technology products that are bound to a tender, the precise specification is particularly important.

This Current is also a roof drainage technology product description, including the LORO-X data sheet with the precise, uniform features and feature values of each LORO-X roof drainage system, which supports a simple selection on the basis of the feature bar through the specification of a roof drainage system with objectively comparable features and illustrates the particular performance of the LORO-X roof drainage systems.

All LORO-X roof drainage systems are described by clear features for system shape and system performance, in particular the shape features, which are important for the performance features.

Series 62 LORO-X DRAINJET-Parapet without penetration into the roof

The 6 star optimisation qualities



Fast



Even with a low water level of just 15 mm above the congestion element, the patented weir under the hood ensures a strong discharge from the roof in case of emergency drainage. Ideal for roofs with a lightweight construction.

Sturdy

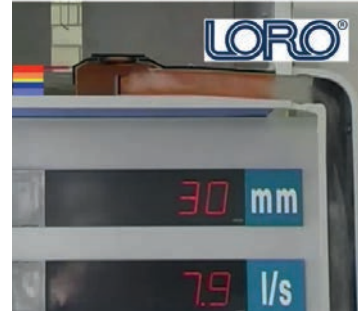

The suction effect of the downpipe propagates throughout the closed siphonic flow system as far as the drain and provides for a strong discharge from the roof.

Video at www.loro.de -> Service

Quiet



The patented suction cover enables a controlled water/air mixture that minimises cavitation and noise development.

Safe

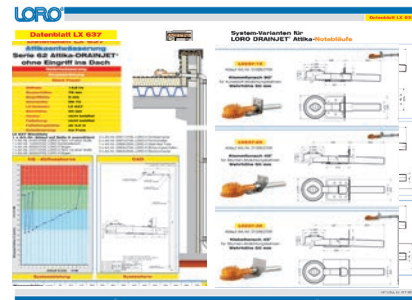

Each complete system includes, as a proof of performance, a head-discharge curve measured under realistic conditions, which you can take from the respective LX specification sheet.

Space-saving

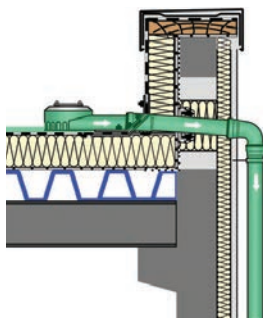

The drainage without penetration into the roof is also ideal for use with 'flat' thermal insulation. Since the complete system is mounted externally, the interior of the building can be freely used.

Money-saving



The high discharge rate even with a small nominal diameter reduces the number of necessary drains and pipes, making significant reductions possible in material usage and effort for the installation.

	Main drainage	
	Siphone flow	
Silent-Power		
Roof penetration 	 0 mm	 0 mm
Diameter	DN 50	DN 70
LX-Number	LX 789	LX 636
Flange form	Clamping flange 90°	Clamping flange 90°
	Clamping flange 45°	Clamping flange 45°
	Bonding flange 45°	Bonding flange 45°
Weir height h [mm] 	0 mm	0 mm
Water height h [mm] <ul style="list-style-type: none"> stark > 75mm mittel < 55mm gering < 35mm 	55 mm	55 mm
Roof area A [m²]*	233	533
Discharge Q [l/sec] 	7,0 l/sec	16,0 l/sec
Schall (dB) 	Silent-Power	Silent-Power

*Assumptions: The roof area is calculated on the basis of the following assumptions:
 local rainfall intensity, normal rain: $r_5 = 0.03 \text{ l/s/m}^2$
 local rainfall intensity, heavy rain: $r_{100} = 0.06 \text{ l/s/m}^2$
 Discharge coefficient $C = 1$ for smooth roof surfaces

Emergency drainage							
Gravity flow				Siphonic flow			
Silent				Silent-Power			
							
 <p>0 mm</p>				 <p>0 mm</p>			
DN 50	DN 50	DN 70	DN 70	DN 50	DN 50	DN 70	
LX 1584	LX 1585	LX 1607	LX 1587	LX 1326	LX 1327	LX 637	
Clamping flange 90°	Clamping flange 90°	Clamping flange 90°	Clamping flange 90°	Clamping flange 90°	Clamping flange 90°	Clamping flange 90°	
Clamping flange 45°	Clamping flange 45°	Clamping flange 45°	Clamping flange 45°	Clamping flange 45°	Clamping flange 45°	Clamping flange 45°	
Bonging flange 45°	Bonging flange 45°	Bonging flange 45°	Bonging flange 45°	Bonging flange 45°	Bonging flange 45°	Bonging flange 45°	
40 mm	60 mm	40 mm	60 mm	40 mm	60 mm	50 mm	
75 mm	75 mm	75 mm	75 mm	75 mm	75 mm	75 mm	
33	33	46	43	283	283	483	
1,0 l/sec	1,0 l/sec	1,4 l/sec	1,3 l/sec	8,5 l/sec	8,5 l/sec	14,5 l/sec	
Silent	Silent	Silent	Silent	Silent-Power	Silent-Power	Silent-Power	

Save energy with know-how: LORO-X DRAINJET-Parapet drainage systems without penetration into the roof

Selected and installed – with a measured proof of performance

"With reliable siphonic flow via the parapet", designers and contractors can maximise the effectiveness and cost savings through the drainage of your projects, particularly in relation to refurbishment and emergency drainage.

The high-performance prefabricated parapet drainage system, as a construction kit from the discharge to the outlet, can be installed on every building with a parapet roof according to the measured system shape.

1. Selection (feature bar)

All important features for the selection can be found in the feature bar in the LX specification sheet. On the basis of the roof structure and the required discharge rate, the selection of a suitable complete system can be accomplished in a few minutes (e.g. by online calculation and configurator at www.loro.de).

2. Quotation (bill of materials)

On the basis of the bill of materials for the prefabricated roof drainage system in the LX specification sheet, a quotation can be prepared in a few minutes (e.g. by online tender). All system parts are hydraulically matched to one another. The height of the downpipe can be adapted to the building, but should be at least 4.2 m (according to measurement) for siphonic flow.

3. Installation (system drawing)

Since the high system performance is directly connected to the system shape, no system part may be exchanged within the chain of planning, ordering and installation without a prior hydraulic test! The complete system drawing, consisting of drains, pipes and fittings in the LX specification sheet, simplifies the coordination between all the trades on the building site. All LORO-X prefabricated roof drainage systems are pressure-resistant and backflow-safe, sustainable and dimensionally stable and are made of break-proof and shock-proof steel.

...with measured proof of performance (head-discharge curve)

Through the measurement of the prefabricated roof drainage system on one of the LORO-X test fields, the discharge rate is reliably proven and documented in the LX specification sheet as a head-discharge curve. This clear and standard-compliant proof of performance offers security for insurers and customers.

For each prefabricated roof drainage system there is an LX specification sheet available at www.loro.de as a PDF document for printing or mailing.

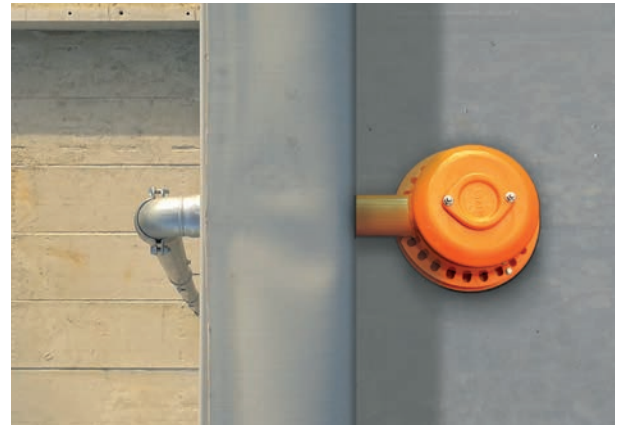

LORO® LORO-DRAINJET® Attika-Schnellablaufsysteme
Datenblatt LX 637

Datenblatt LX 637
Attikaentwässerung
Serie 62 Attika-DRAINJET®
ohne Eingriff ins Dach

Notentwässerung	
Druckströmung	
Silent Power	
Abfluss:	14,5 l/s
Wasserhöhe:	75 mm
Eingrifftiefe:	0 mm
Nennweite:	DN 70
LX-Nummer:	LX 637
Wehrhöhe:	60 mm
Haube:	nicht belüftet
Fallleitung:	nicht belüftet
Fallleitungshöhe:	ab 4,2 m
Entwässerung:	ins Freie

LX 637 Stückliste

1 x Art.-Nr. 01461.070X, LORO-X Rohr mit einer Muffe
 1 x Art.-Nr. 13295.070X, LORO-Schiebeflansch
 1 x Art.-Nr. 00350.070X, LORO-X Bogen
 1 x Art.-Nr. 01011.070X, LORO-X Rohr mit einer Muffe
 1 x Art.-Nr. 00320.070X, LORO-X Bogen

4 x Art.-Nr. 00911.070X, LORO-X Dichtelemente
 2 x Art.-Nr. 00973.070X, LORO-X Rohrschellen
 1 x Art.-Nr. 00860.002X, LORO-X Gleitstiel Tube
 3 x Art.-Nr. 00806.070X, LORO-X Sicherungsschellen
 2 x Art.-Nr. 09603.200X, LORO-X Stockschraube

hQ - Abflusskurve

CAD

Wasserhöhe	mm	5	10	15	20	25	30	35	40	45	50	55	60	65	70	75	
Abfluss	l/s							3	5	8	10	13	14,2	14,3	14,4	14,5	
		Silent					Silent Power										

AKTUELL SERIE 62 DJ ATTIKA
10

Example applications:

LORO-X DRAINJET®-Parapet
 without roof penetration,
 DN 70,
 with clamping roof 45° for
 bituminous roofing sheets
 40 mm weir height

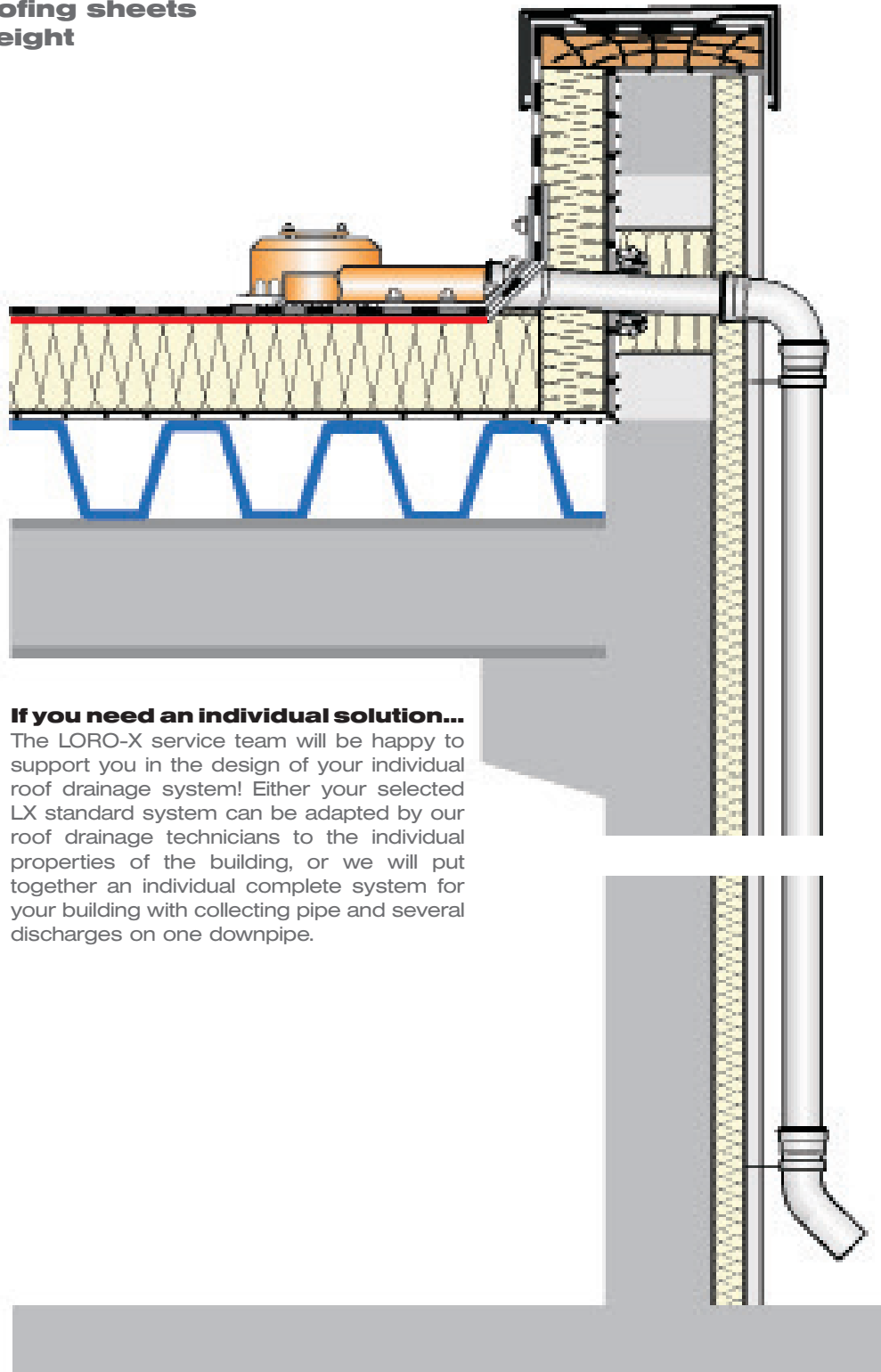

If you need an individual solution...

The LORO-X service team will be happy to support you in the design of your individual roof drainage system! Either your selected LX standard system can be adapted by our roof drainage technicians to the individual properties of the building, or we will put together an individual complete system for your building with collecting pipe and several discharges on one downpipe.

Example applications:

LORO-X DRAINLET®-Parapet

without roof penetration,
 DN 70,
 with clamping flange 45° for
 bituminous roofing sheets
 40 mm weir height

Series 62

Discharge rate as spout:

Emergency drainage: 1.4 l/sec

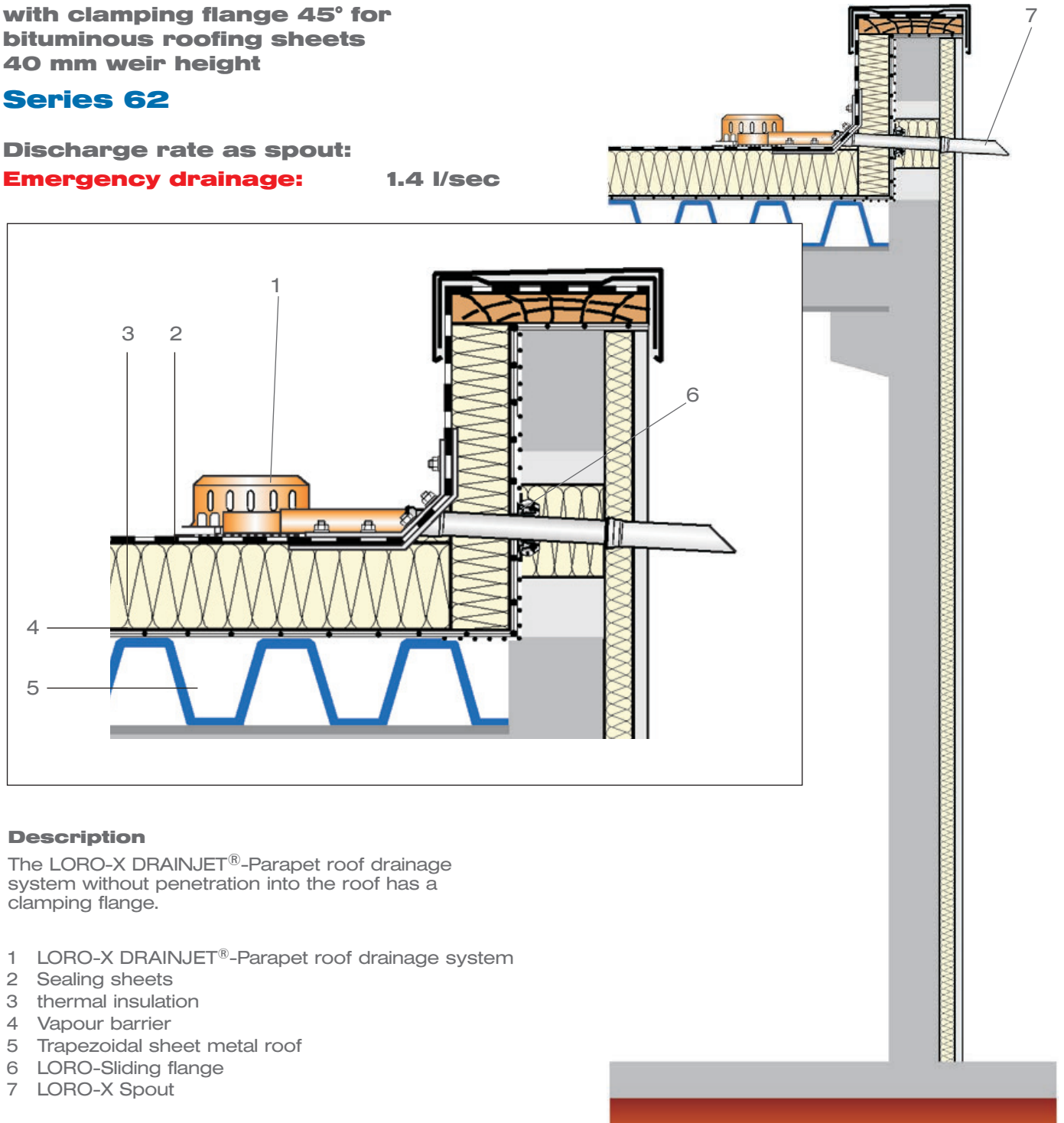

Description

The LORO-X DRAINJET®-Parapet roof drainage system without penetration into the roof has a clamping flange.

- 1 LORO-X DRAINJET®-Parapet roof drainage system
- 2 Sealing sheets
- 3 thermal insulation
- 4 Vapour barrier
- 5 Trapezoidal sheet metal roof
- 6 LORO-Sliding flange
- 7 LORO-X Spout

System form

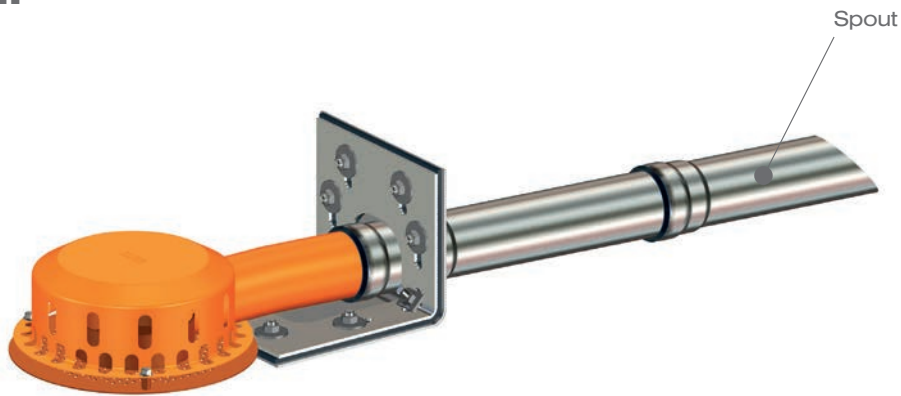

(Picture 1)

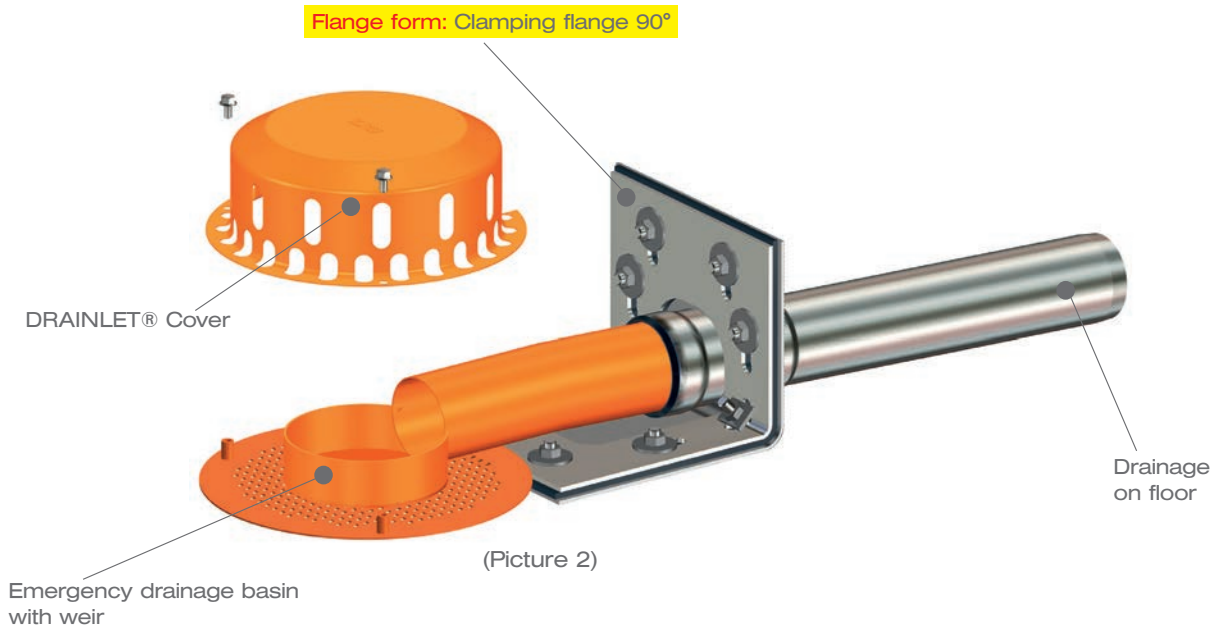

(Picture 2)

The LORO-X DRAINLET-Parapet drainage achieves a high discharge rate without penetration into the roof through the optimised congestion element under the hood.

Due to the large “overflow edge” of the congestion element, more water can discharge through the discharge pipe, which is installed at the same height, than would be possible with conventional spouts (installed higher).

The installation of the emergency drain takes place on the same level as the main drain, as a result of which additional work on the building site to set the emergency drain higher is unnecessary.

Fall 1: normal rain

Main drainage

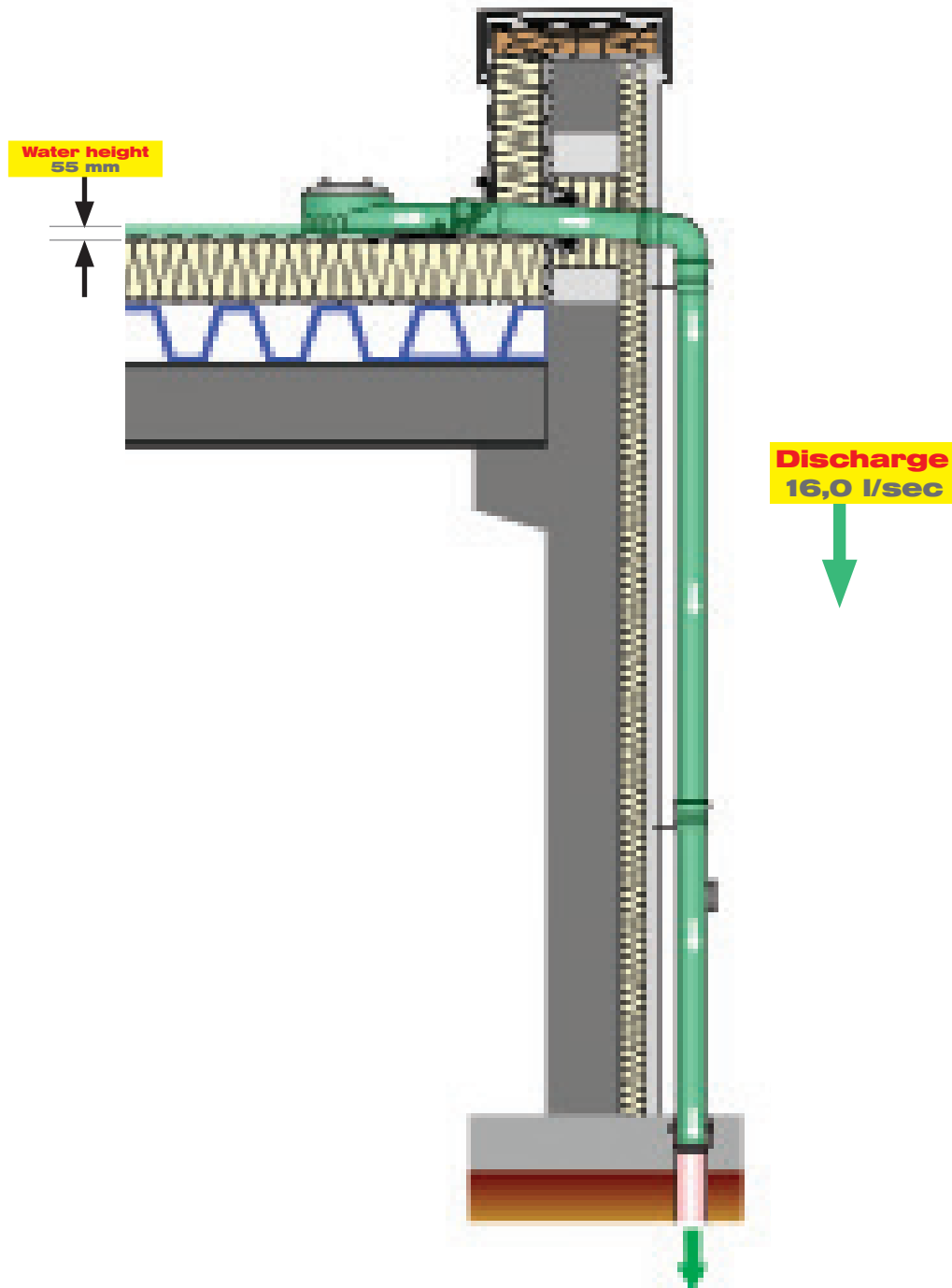

Drainage: in sewer

Fall 2: strong rain

Emergency drainage

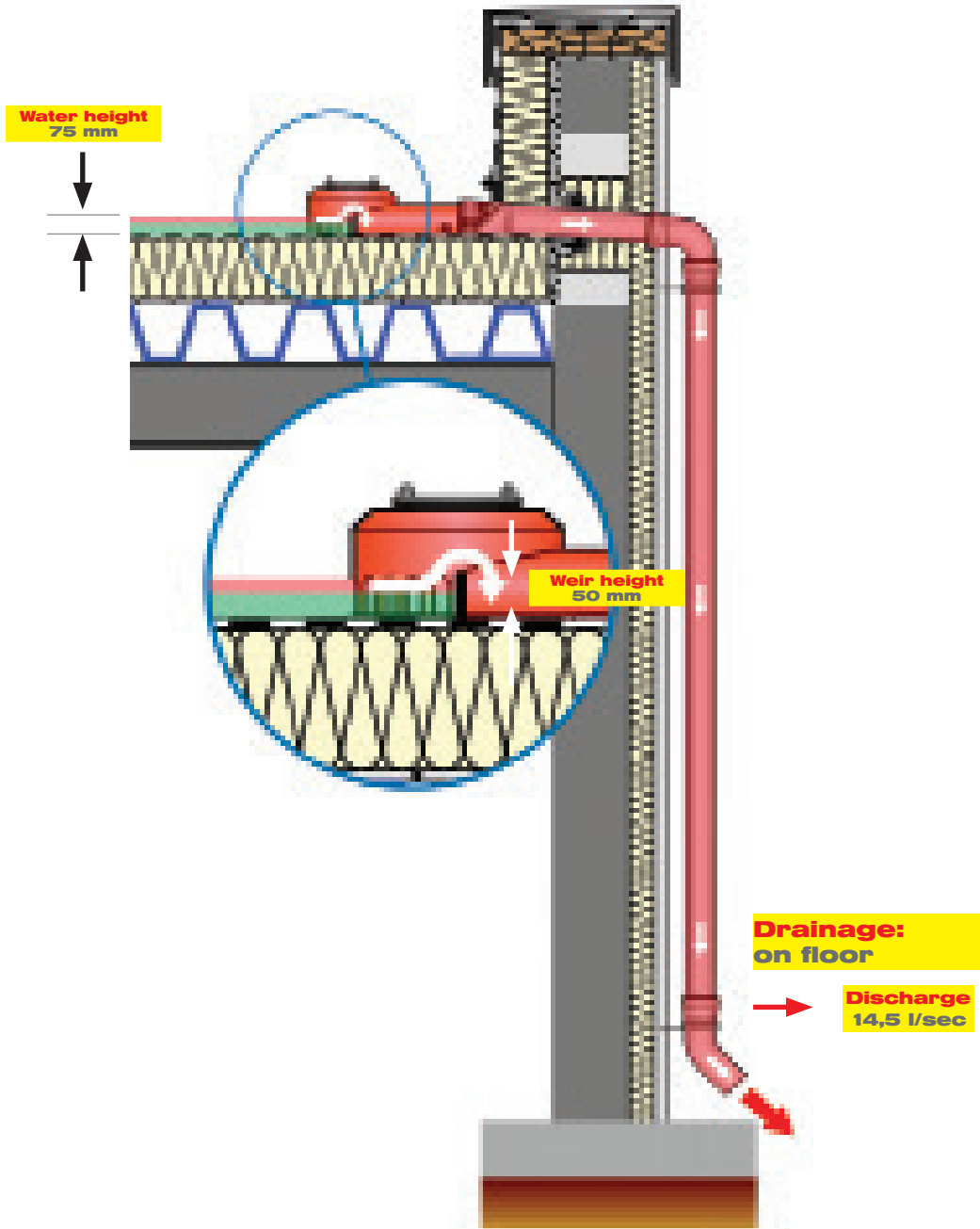

Drainage: on floor

Calculation

Calculation example*

- Parapet roof of a building with effective rainfall area
A = 450 m² (no sub-areas)
- Discharge coefficient c = 1.0
- Rainfall r_{5,5} = 300 l/(s x ha)
- Rainfall r_{5,100} = 600 l/(s x ha)
- Water level for main drainage 55 mm
- Water level for emergency drainage 75 mm
- LORO-X DRAINJET-Parapet with siphonic flow for main and emergency drainage

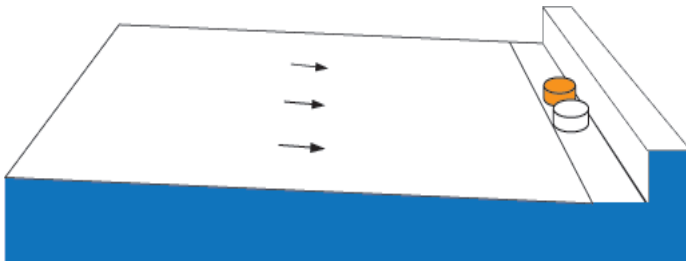
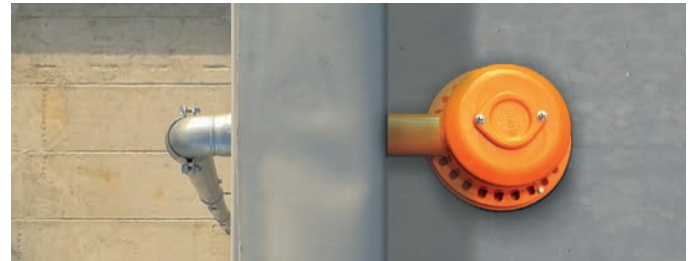

Table 6 – Discharge coefficients C acc. to DIN 1986-100 for determining the rainwater discharge (excerpt)

No.	Type of surfaces	C*
1	Waterproof surfaces, e.g.	1,0
	- Roof areas	1,0
	- Concrete surfaces	1,0
	- Ramps	
	- Surfaces fastened in place with sealed joints	1,0
	- Blacktops (asphalt)	1,0
	- Paving with sealed joints	0,5
	- Gravel roofs	
	- Green roof areas	0,3
	- For intensive green roofs	
	- For extensive green roofs from 10 cm thickness	0,3
	- For extensive green roofs below 10 cm thickness	0,5



Required discharge of the main drainage

Determining the design rainfall intensity:

$$Q_r = \frac{A \cdot r_{5,5} \cdot C}{10000}$$

- Q_r [l/s] = design rainfall intensity
 A [m²] = effective roof surface or partial surface
 r_{5,5} [l/(s · ha)] = Rainfall (5 min, every 5 years)
 C [-] = Discharge coefficient

$$Q_r = \frac{450 \cdot 300 \cdot 1,0}{10000}$$

$$Q_r = 13.5 \text{ l/s}$$

Required discharge of the emergency drainage

Determining the volumetric overflow rate for emergency drains:

$$Q_{em.} = \frac{A \cdot (r_{5,100} - r_{5,5} \cdot C)}{10000}$$

- Q_{em.} [l/s] = volumetric overflow rate
 A [m²] = effective roof surface or partial surface
 r_{5,100} [l/(s · ha)] = Rainfall (5 min, every 5 years)
 C [-] = Discharge coefficient

$$Q_{em.} = \frac{450 \cdot (600 - 300 \cdot 1,0)}{10000}$$

$$Q_{em.} = 13.5 \text{ l/s}$$

Discharge values from

Specific. sheet LX 636
Specific. sheet LX 637

for the LORO-X DRAINJET-Parapet drainage

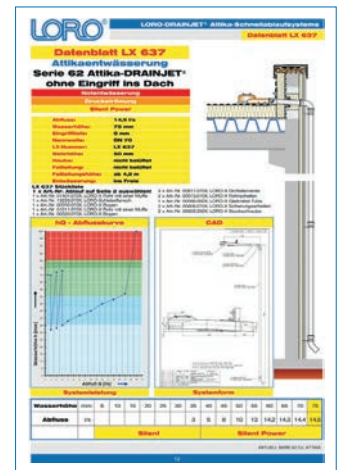
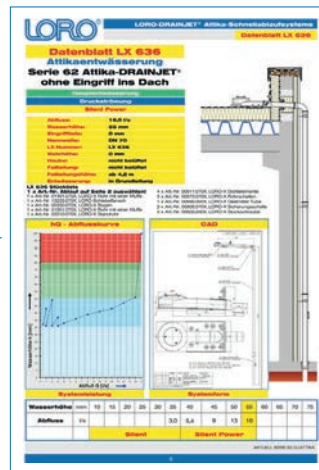

Available discharge of the **main drainage**

$$Q_{DA \text{ Main}} = 16.0 \text{ l/s}$$

Available discharge of the **emergency drainage**

$$Q_{DA \text{ Em.}} = 14.5 \text{ l/s}$$

Determination of the number of discharges for the **main drainage**

$$n_{DA} = \frac{Q_r}{Q_{DA \text{ Main}}} \text{ number of items}$$

- n_{DA} [-] = number of main drainages
- Q_r [l/s] = discharge of the main drainage
- $Q_{DA \text{ Main}}$ [l/s] = discharge of a main drainage with a specified water level of 35 mm at the main drain

$$n_{DA} = \frac{13.5 \text{ l/s}}{16.0 \text{ l/s}} = 1\text{-off}$$

Determination of the number of discharges for the **emergency drainage**

$$n_{Em.} = \frac{Q_{Em.}}{Q_{DA \text{ Em.}}} \text{ number of items}$$

- $n_{Em.}$ [-] = number of emergency drainages
- $Q_{Em.}$ [l/s] = discharge of the emergency drainage
- $Q_{DA \text{ Em.}}$ [l/s] = discharge of an emergency drainage with a specified water level of 75 mm at the emergency drain

$$n_{Em.} = \frac{13.5 \text{ l/s}}{14.5 \text{ l/s}} = 1\text{-off}$$

Number of LORO-X DRAINJET-Parapet required

Main drainages = 1-off

Emergency drainages = 1-off

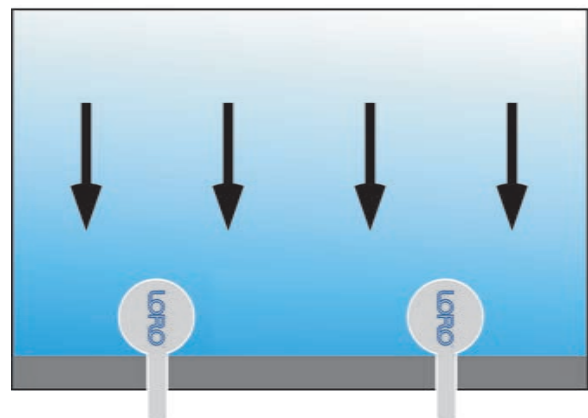

Please contact the LORO-X internal and field service team if you have any questions about the design of roof drainage.

Siphonic flow

Dimensions and weights

LORO-DRAINJET®
Siphonic parapet drain,
Series 62,
DN 50 and DN 70,
with clamping flange,
for bituminous roofing sheets

made of stainless steel

Discharge rate according to specification sheet:

LX 789 DN 50: 7,0 l/sec*
LX 636 DN 70: 16,0 l/sec*

DN 50: Art-No. 01347.050X Weight: 8,4 kg
 DN 70: Art-No. 01347.070X Weight: 9,1 kg

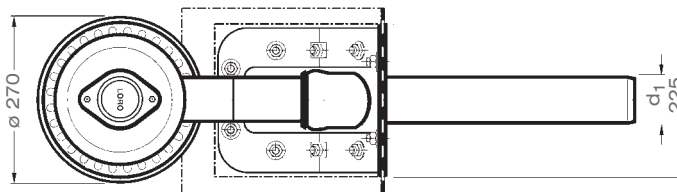
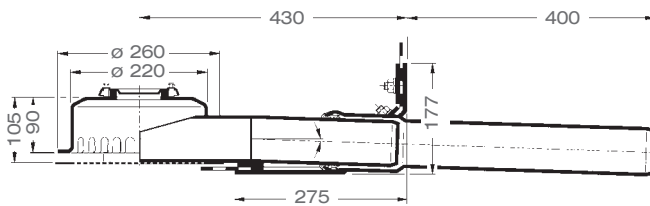
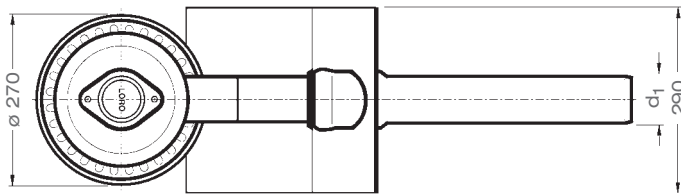
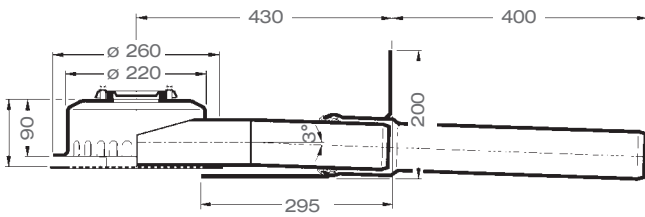

with clamping flange,
for bituminous roofing sheets

made of stainless steel

Discharge rate according to specification sheet:

LX 789 DN 50: 7,0 l/sec*
LX 636 DN 70: 16,0 l/sec*

DN 50: Art-No. 01351.050X Weight: 5,7 kg
 DN 70: Art-No. 01351.070X Weight: 6,5 kg

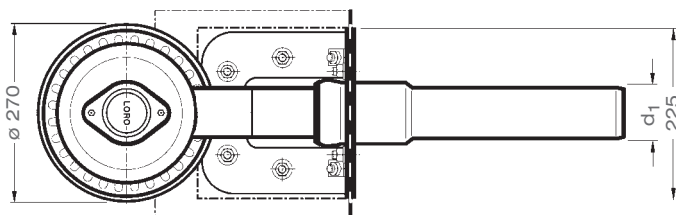
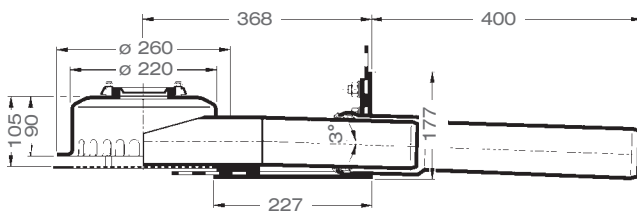

with clamping flange,
for plastic roofing sheets

made of stainless steel

Discharge rate according to specification sheet:

LX 789 DN 50: 7,0 l/sec*
LX 636 DN 70: 16,0 l/sec*

DN 50: Art-No. 01353.050X Weight: 8,8 kg
 DN 70: Art-No. 01353.070X Weight: 9,2 kg

DN	d ₁	h
50	53	40
70	73	52

* Test specification according to DIN EN 1253

Siphonic flow

Dimensions and weights

LORO-DRAINJET[®]
Siphonic parapet emergency drain,
Series 62,
weir height 40 mm, DN 50
with bonding flange,
for bituminous roofing sheets

made of stainless steel

Discharge rate according to specification sheet:

LX1326 DN 50: 8,5 l/sec*

DN 50: [Art.-No. 01349.050X](#) Weight: 8,7 kg

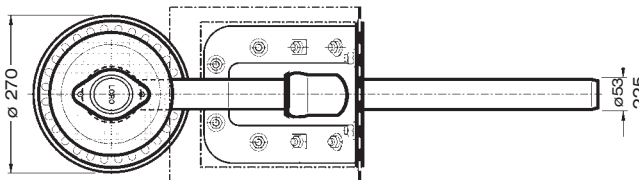
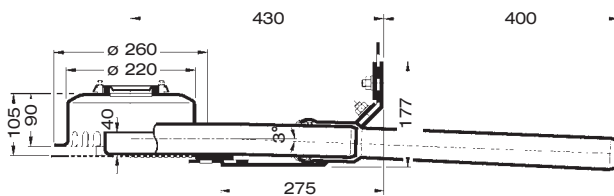
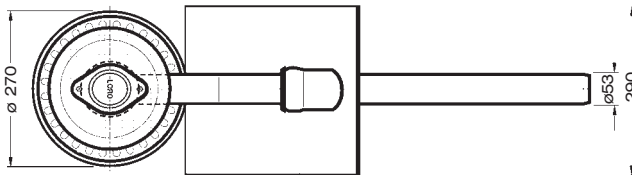
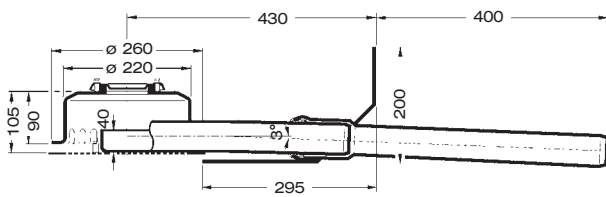

with clamping flange,
for bituminous roofing sheets

made of stainless steel

Discharge rate according to specification sheet:

LX1326 DN 50: 8,5 l/sec*

DN 50: [Art.-No. 01356.050X](#) Weight: 8,7 kg

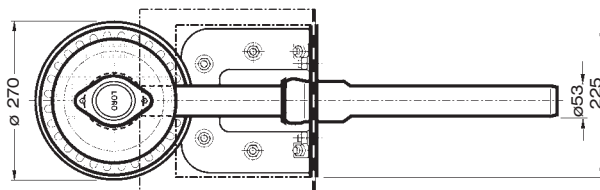
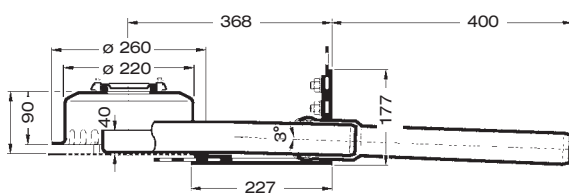

with clamping flange,
for plastic roofing sheets

made of stainless steel

Discharge rate according to specification sheet:

LX1326 DN 50: 8,5 l/sec*

DN 50: [Art.-No. 01358.050X](#) Weight: 8,7 kg

* Test specification according to DIN EN 1253

Siphonic flow

Dimensions and weights

LORO-DRAINJET[®]
Siphonic parapet emergency drain,
Series 62,
weir height 60 mm DN 50,
with bonding flange,
for bituminous roofing sheets

made of stainless steel

Discharge rate according to specification sheet:

LX1327 DN 50: 8,5 l/sec*

DN 50: Art.-No. 01387.050X Weight: 6,0 kg

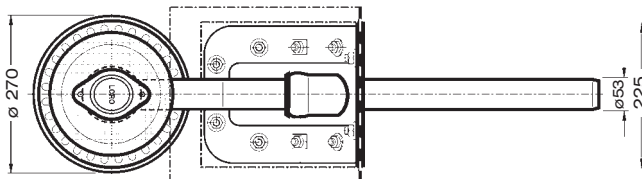
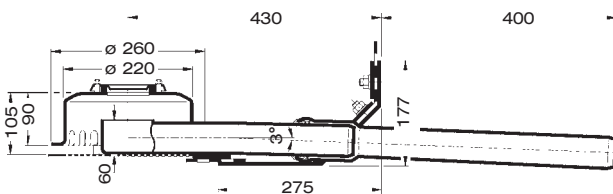
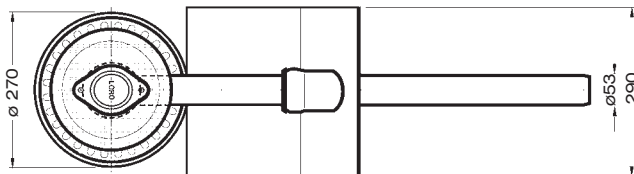
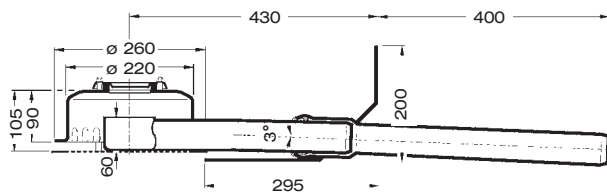

with clamping flange,
for bituminous roofing sheets

made of stainless steel

Discharge rate according to specification sheet:

LX1327 DN 50: 8,5 l/sec*

DN 50: Art.-No. 01359.050X Weight: 8,7 kg

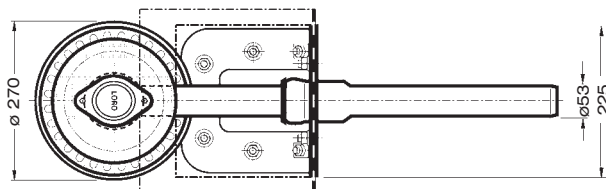
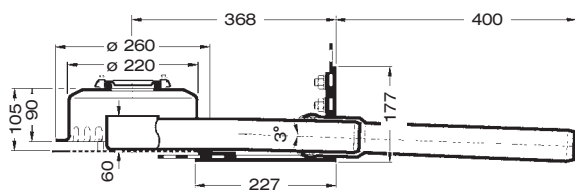

with clamping flange,
for plastic roofing sheets

made of stainless steel

Discharge rate according to specification sheet:

LX1327 DN 50: 8,5 l/sec*

DN 50: Art.-No. 01375.050X Weight: 8,7 kg

Siphonic flow

Dimensions and weights

LORO-DRAINJET®
Siphonic parapet emergency
drain, Series 62,
weir height 50 mm DN 70,
with bonding flange,
for bituminous roofing sheets

made of stainless steel

Discharge rate according to
specification sheet:

LX637 DN 70: 14,5 l/sec*

DN 50: [Art-No. 01349.070X](#) Weight: 6,0 kg

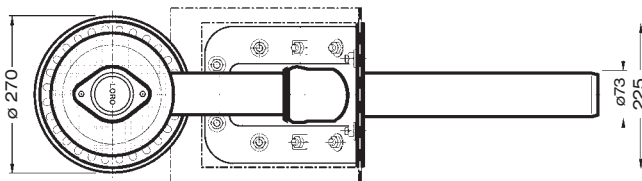
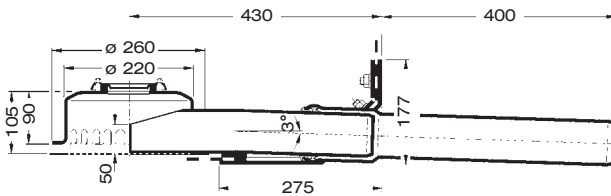
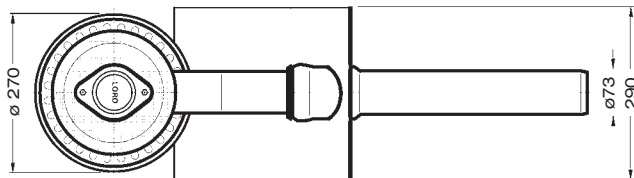
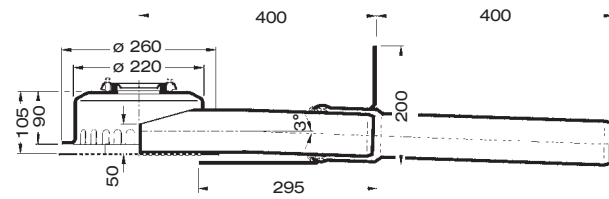

with clamping flange,
for bituminous roofing sheets

made of stainless steel

Discharge rate according to
specification sheet:

LX637 DN 70: 14,5 l/sec*

DN 50: [Art-Nr. 01356.070X](#) Gewicht: 8,7 kg

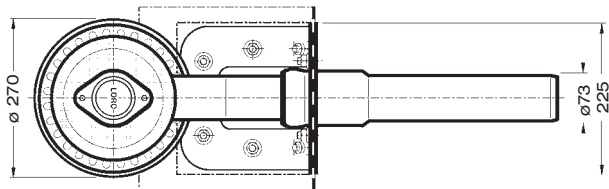
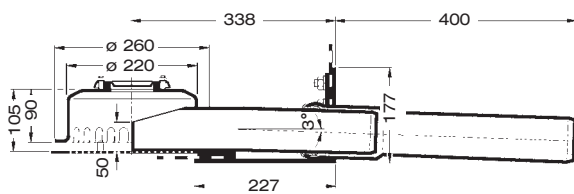

with clamping flange,
for plastic roofing sheets

made of stainless steel

Discharge rate according to
specification sheet:

LX637 DN 70: 14,5 l/sec*

DN 50: [Art-No. 01358.070X](#) Weight: 8,7 kg

Gravity flow

Dimensions and weights

LORO-DRAINLET®
Parapet emergency drain,
Series 62,
weir height 40 mm DN 50, DN 70,
with bonding flange,
for bituminous roofing sheets

made of stainless steel

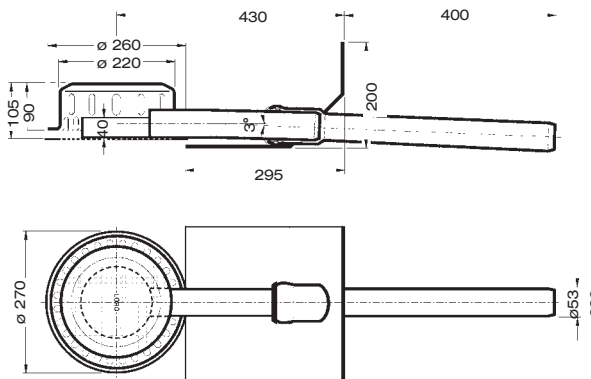

Discharge rate according to specification sheet:

LX1584 DN 50: 1,0 l/sec
LX1607 DN 70: 1,4 l/sec

DN 50: [Art.-No. 01397.050X](#) Weight: 6,0 kg
 DN 70: [Art.-No. 01397.070X](#) Weight: 6,0 kg

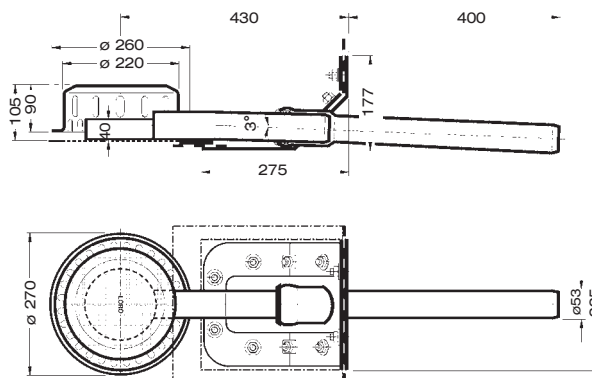

with clamping flange,
for bituminous roofing sheets

made of stainless steel

Discharge rate according to specification sheet:

LX1584 DN 50: 1,0 l/sec
LX1607 DN 70: 1,4 l/sec

DN 50: [Art.-No. 01355.050X](#) Weight: 6,0 kg
 DN 70: [Art.-No. 01355.070X](#) Weight: 6,0 kg

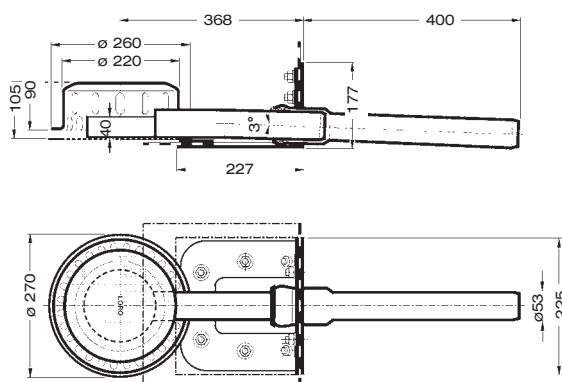

with clamping flange,
for plastic roofing sheets

made of stainless steel

Discharge rate according to specification sheet:

LX1584 DN 50: 1,0 l/sec
LX1607 DN 70: 1,4 l/sec

DN 50: [Art.-No. 01341.050X](#) Weight: 6,0 kg
 DN 70: [Art.-No. 01341.070X](#) Weight: 6,0 kg

Gravity flow

Dimensions and weights

LORO-DRAINLET[®]
Parapet emergency drain,
Series 62,
weir height 60 mm DN 50, DN 70,
with bonding flange,
for bituminous roofing sheets

made of stainless steel

Discharge rate according to specification sheet:

LX1585 DN 50: 1,0 l/sec

LX1587 DN 70: 1,3 l/sec

DN 50: Art.-No. 01398.050X Weight: 6,0 kg

DN 70: Art.-No. 01398.070X Weight: 6,0 kg

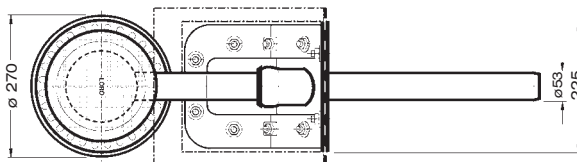
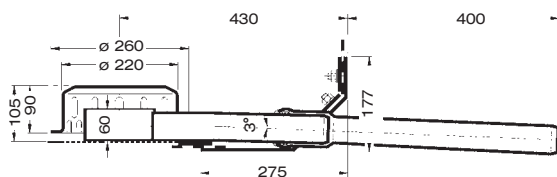
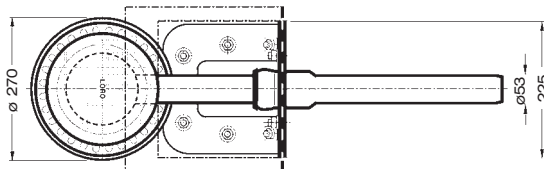
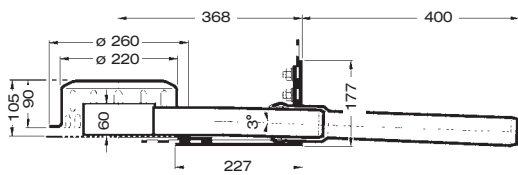

with clamping flange,
for bituminous roofing sheets

made of stainless steel

Discharge rate according to specification sheet:

LX1585 DN 50: 1,0 l/sec

LX1587 DN 70: 1,3 l/sec

DN 50: Art.-No. 01357.050X Weight: 6,0 kg

DN 70: Art.-No. 01357.070X Weight: 6,0 kg

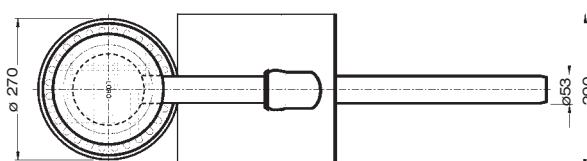
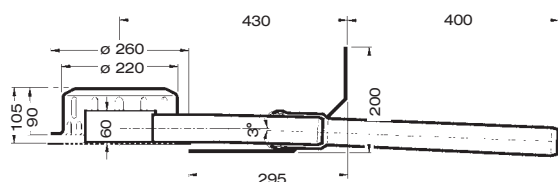

with clamping flange,
for plastic flange

made of stainless steel

Discharge rate according to specification sheet:

LX1585 DN 50: 1,0 l/sec

LX1587 DN 70: 1,3 l/sec

DN 50: Art.-No. 01347.050X Weight: 6,0 kg

DN 70: Art.-No. 01347.070X Weight: 6,0 kg

Specification sheet LX 789

Siphonic Parapet drains

Series 62 DRAINJET®

without roof penetration

Main Drainage

Siphonic flow

Silent Power

Discharge rate:	7,0 l/sec
Water height:	55 mm
Roof penetration:	0 mm
Diameter:	DN 50
LX-Number:	LX 789
Weir height:	0 mm
Drain:	not ventilated
Downpipe:	not ventilated
Downpipe height:	min 4,2 m
Drainage:	in sewer

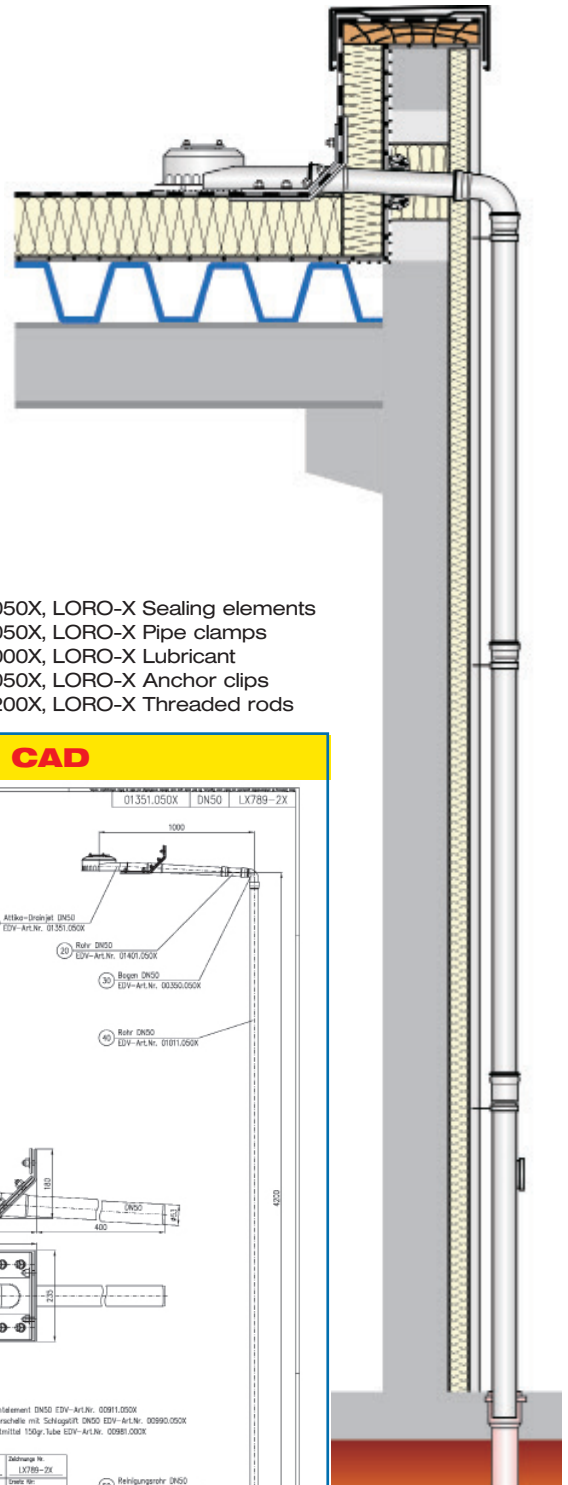

LX 789 Piece list

- 1 x Art.-No. choose drain on page two!
- 1 x Art.-No. 01401.050X, LORO-X Pipe with one socket
- 1 x Art.-No. 13232.050X, LORO-Sliding flange
- 1 x Art.-No. 00350.050X, LORO-X Bend
- 1 x Art.-No. 01101.050X, LORO-X Pipe with one socket
- 1 x Art.-No. 00550.050X, LORO-X Cleaning pipe

- 4 x Art.-No. 00911.050X, LORO-X Sealing elements
- 3 x Art.-No. 00973.050X, LORO-X Pipe clamps
- 1 x Art.-No. 00986.000X, LORO-X Lubricant
- 2 x Art.-No. 00806.050X, LORO-X Anchor clips
- 3 x Art.-No. 09603.200X, LORO-X Threaded rods

hQ - Head-Discharge curve

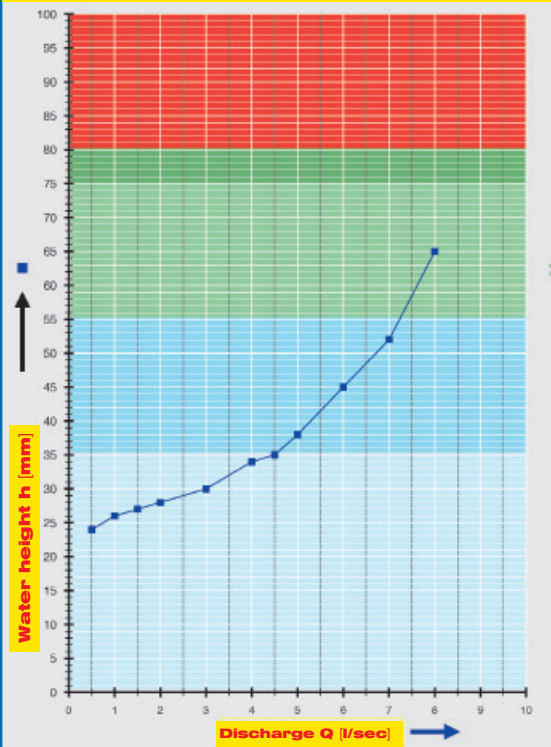

Systempower

CAD

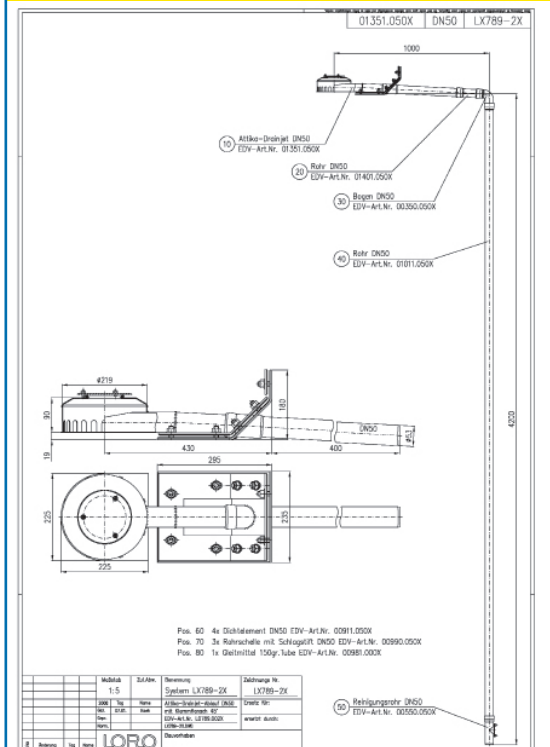

Systemshape

Water height	mm	5	10	15	20	25	30	35	40	45	50	55	60	65	70	75
Discharge	l/sec					0,75	3	4,5	5,3	6	6,7	7,2	7,7	8		
		Silent						Silent Power								

Choose drain for piece list on page one!

LX789-1X

Drain Art.-No. 01358.050X

clamping flange 90°
for plastic roofing sheets

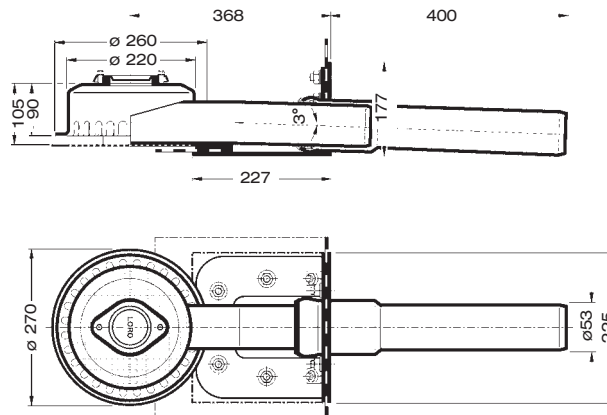

LX789-2X

Drain Art.-No. 01351.050X

clamping flange 45°
for bituminous roofing sheets

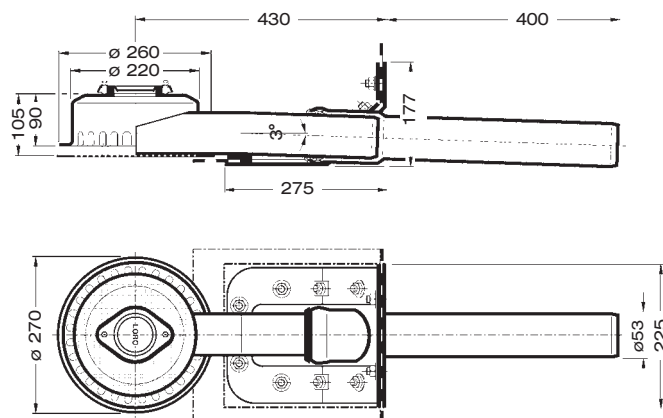

LX789-3X

Drain Art.-No. 01347.050X

bonding flange 45°
for bituminous roofing sheets

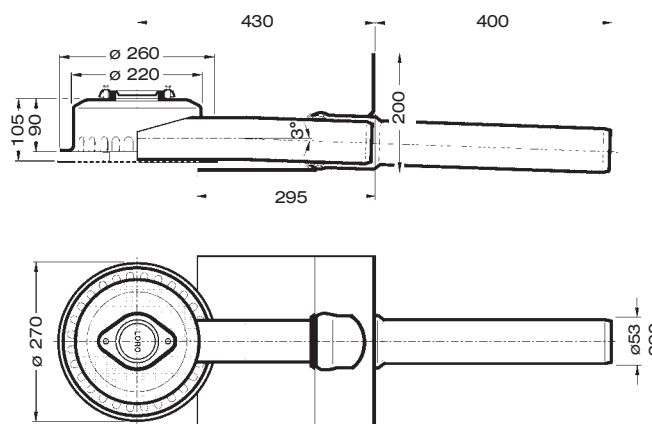

Please note:

For drainage systems with siphonic flow it is vital that only LORO-X pipes and fittings in the combination as indicated are used. Mixture or exchange of system parts may result in lower discharge capacities! The height of the downpipe must be a min. 4.2m for the indicated capacity to be obtained. If roof drain and downpipe are fitted by different crews, then do follow the system setup acc. to the LX-data sheet at www.loro-x.com

Heat tracing: Lorowerk recommends to check all drains and pipes with regard to their frost-sensibility. Where necessary, these parts should be upgraded with heat tracing.

Specification sheet LX 636

Siphonic Parapet drains

Series 62 DRAINJET®

without roof penetration

Main Drainage

Siphonic flow

Silent Power

Discharge rate:	16,0 l/sec
Water height:	55 mm
Roof penetration:	0 mm
Diameter:	DN 70
LX-Number:	LX 636
Weir height:	0 mm
Drain:	not ventilated
Downpipe:	not ventilated
Downpipe height:	min 4,2 m
Drainage:	in sewer

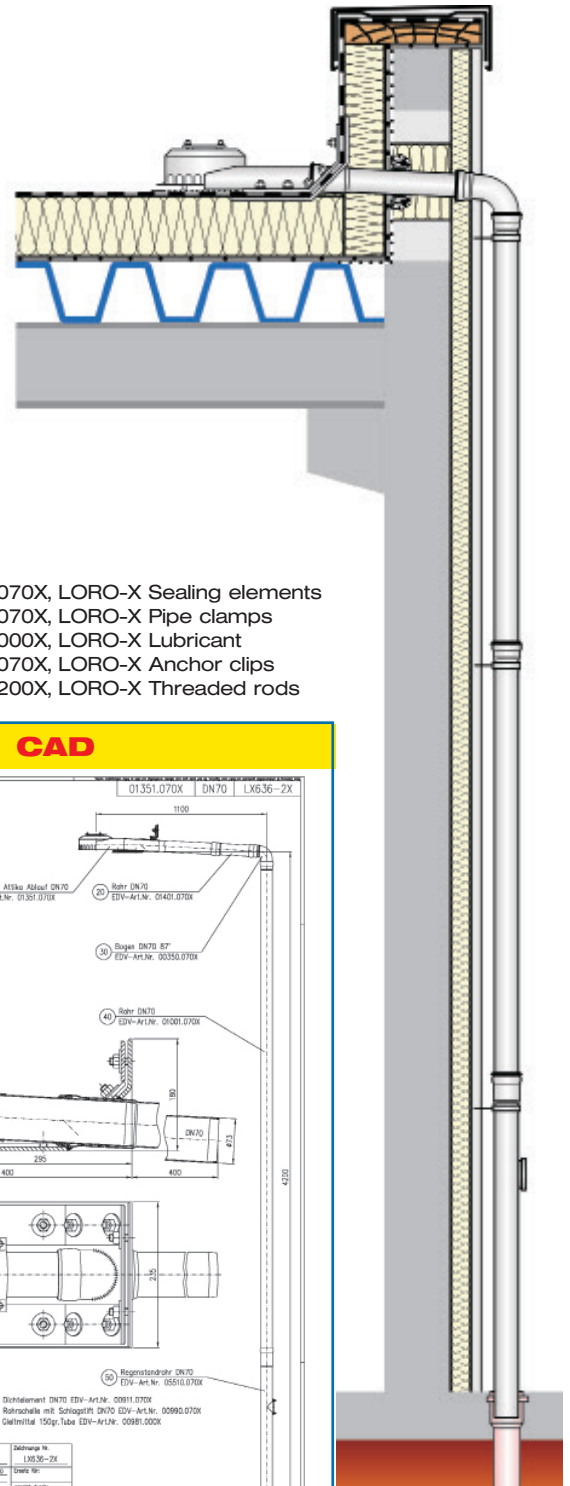

LX 636 Piece list

- 1 x Art.-No. **choose drain on page two!**
- 1 x Art.-No. 01401.070X, LORO-X Pipe with one socket
- 1 x Art.-No. 13235.070X, LORO-Sliding flange
- 1 x Art.-No. 00350.070X, LORO-X Bend
- 1 x Art.-No. 01001.070X, LORO-X Pipe with one socket
- 1 x Art.-No. 05510.070X, LORO-X Stand pipe

- 4 x Art.-No. 00911.070X, LORO-X Sealing elements
- 3 x Art.-No. 00973.070X, LORO-X Pipe clamps
- 1 x Art.-No. 00986.000X, LORO-X Lubricant
- 2 x Art.-No. 00806.070X, LORO-X Anchor clips
- 3 x Art.-No. 09603.200X, LORO-X Threaded rods

hQ - Head-Discharge curve

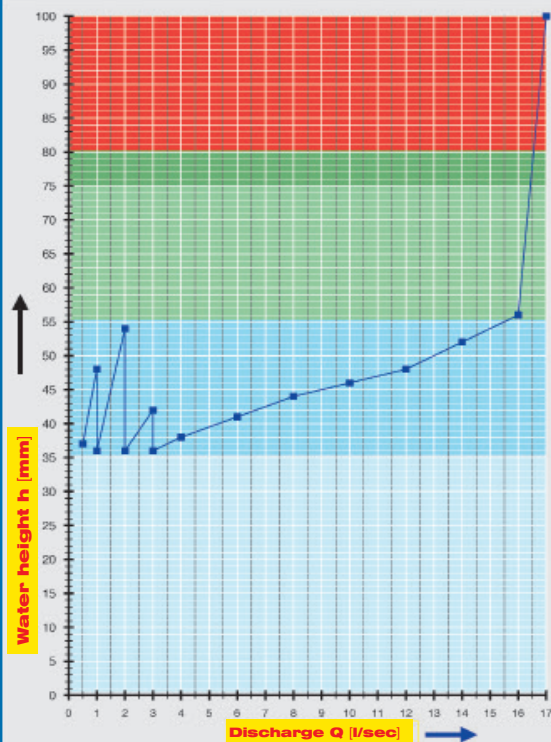

Systempower

CAD

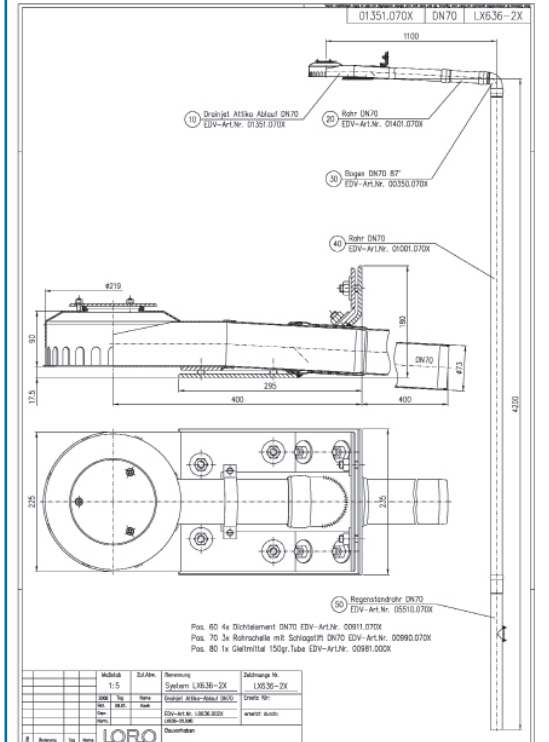

Systemshape

Water height	mm	10	15	20	25	30	35	40	45	50	55	60	65	70	75
Discharge	l/sec						3,0	5,4	9	13	16				
		Silent					Silent Power								

Choose drain for piece list on page one!

LX636-1X

Drain Art.-No. 01358.070X

clamping flange 90°
for plastic roofing sheets

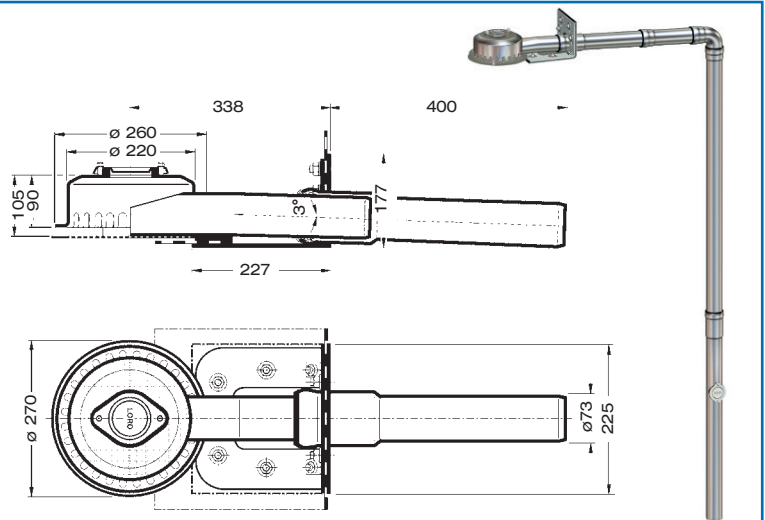

LX636-2X

Drain Art.-No. 01351.070X

clamping flange 45°
for bituminous roofing sheets

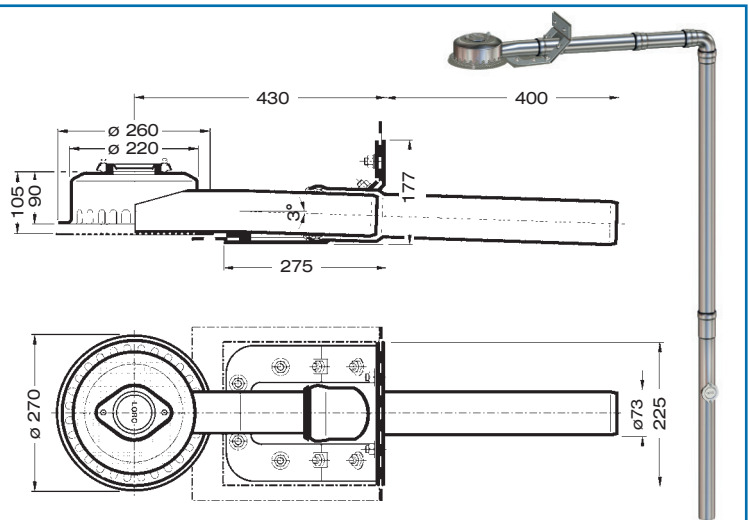

LX636-3X

Drain Art.-No. 01347.070X

bonding flange 45°
for bituminous roofing sheets

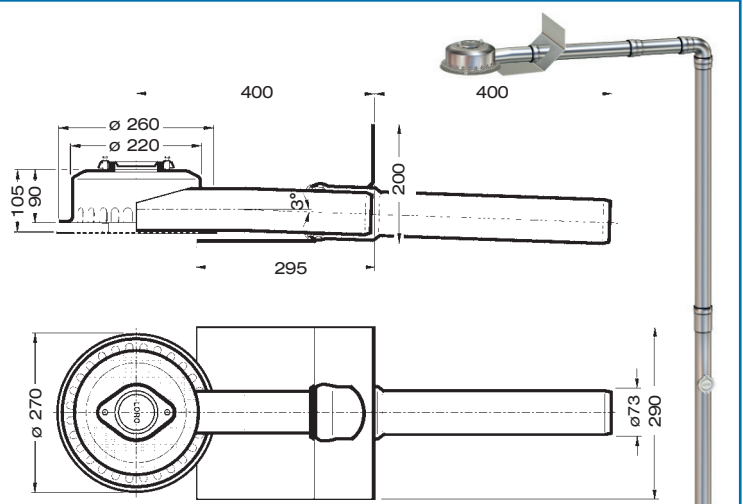

Please note:

For drainage systems with siphonic flow it is vital that only LORO-X pipes and fittings in the combination as indicated are used. Mixture or exchange of system parts may result in lower discharge capacities! The height of the downpipe must be a min. 4.2m for the indicated capacity to be obtained. If roof drain and downpipe are fitted by different crews, then do follow the system setup acc. to the LX-data sheet at www.loro-x.com

Heat tracing: Lorowerk recommends to check all drains and pipes with regard to their frost-sensibility. Where necessary, these parts should be upgraded with heat tracing.

Specification sheet LX 1326

Siphonic Parapet drains Series 62 DRAINJET[®] without roof penetration

Emergency drainage

Siphonic flow

Silent Power

Discharge rate:	8,5 l/sec
Water height:	75 mm
Roof penetration:	0 mm
Diameter:	DN 50
LX-Number:	LX 1326
Weir height:	40 mm
Drain:	not ventilated
Downpipe:	not ventilated
Downpipe height:	min 4,2 m
Drainage:	on floor

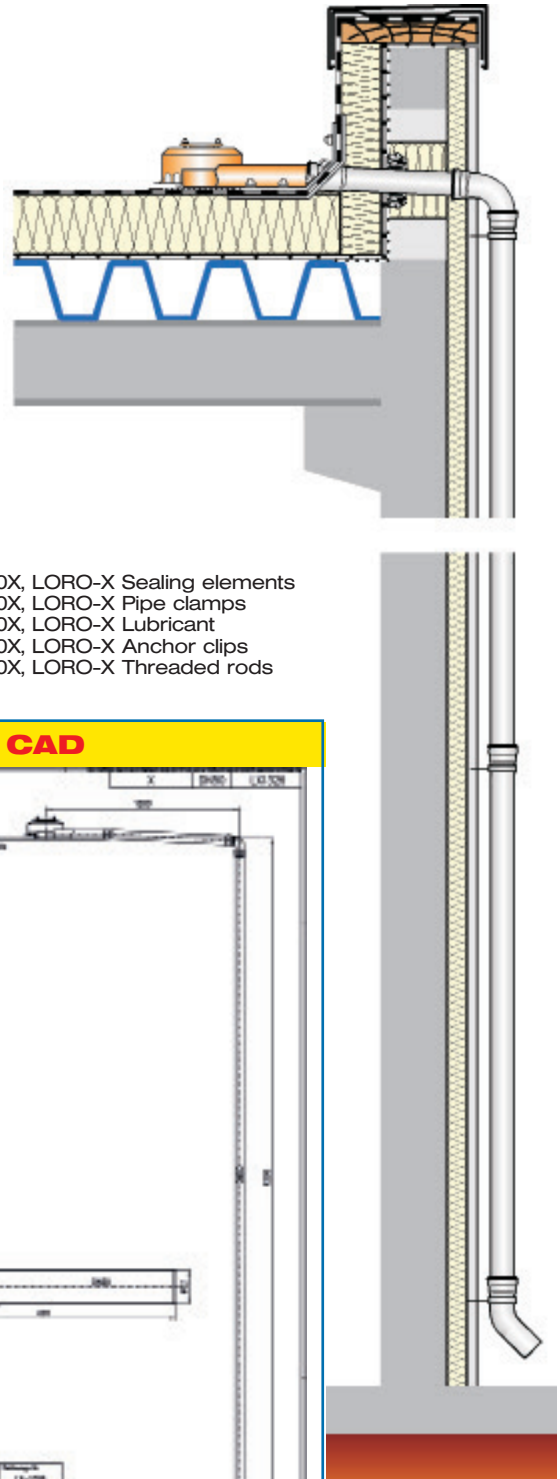

LX 1326 Piece list

1 x Art.-No. choose drain on page two!

- 1 x Art.-No. 01401.050X, LORO-X Pipe with one socket
- 1 x Art.-No. 13232.050X, LORO-Sliding flange
- 1 x Art.-No. 00350.050X, LORO-X Bend
- 1 x Art.-No. 01011.050X, LORO-X Pipe with one socket
- 1 x Art.-No. 00320.050X, LORO-X Bend

- 4 x Art.-No. 00911.050X, LORO-X Sealing elements
- 2 x Art.-No. 00973.050X, LORO-X Pipe clamps
- 1 x Art.-No. 00986.000X, LORO-X Lubricant
- 3 x Art.-No. 00806.050X, LORO-X Anchor clips
- 2 x Art.-No. 09603.200X, LORO-X Threaded rods

hQ - Head-Discharge curve

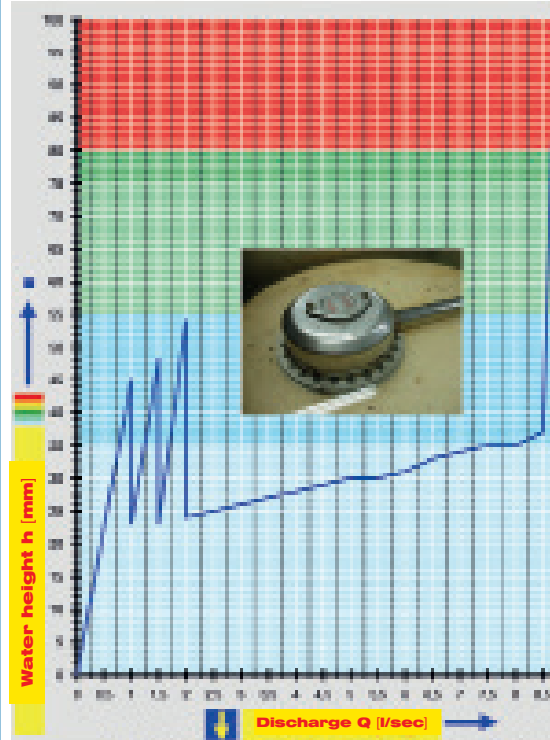

Systempower

CAD

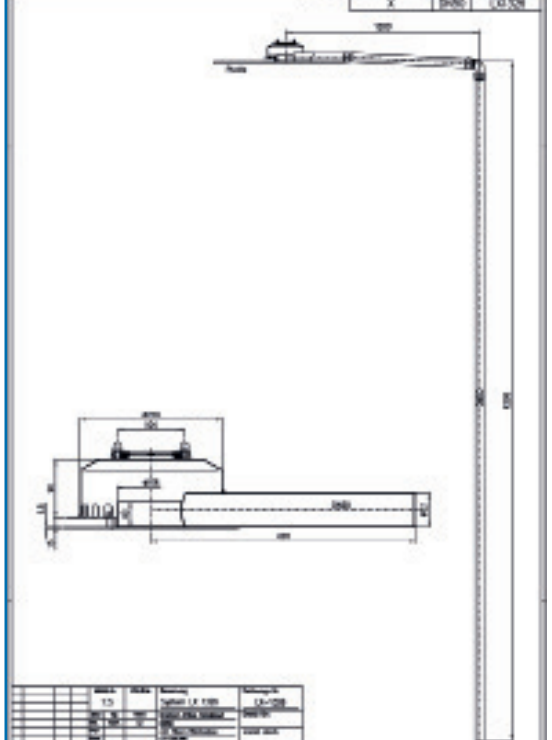

Systemshape

Water height	mm	10	15	20	25	30	35	40	45	50	55	60	65	70	75
Discharge	l/sec										8,5	8,5	8,5	8,5	8,5
		Silent				Silent Power									

Choose drain for piece list on page one!

LX1326-1X

Drain Art.-No. 01358.050X

clamping flange 90°
for plastic roofing sheets
Weir height 40 mm

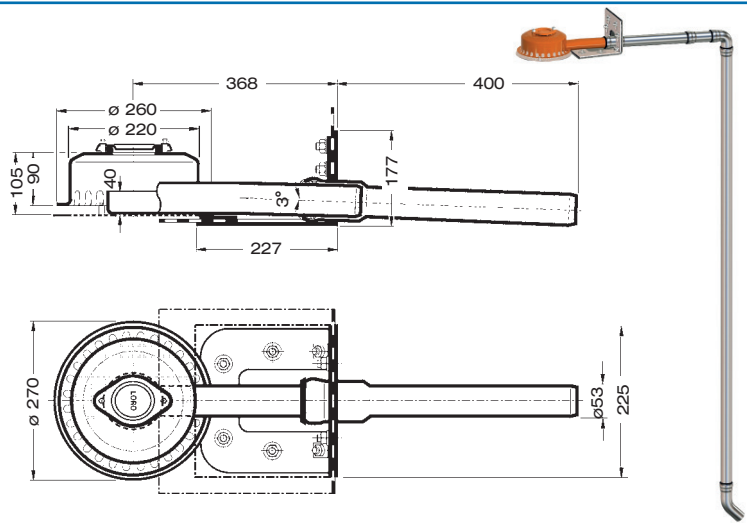

LX1326-2X

Drain Art.-No. 01356.050X

clamping flange 45°
for bituminous roofing sheets
Weir height 40 mm

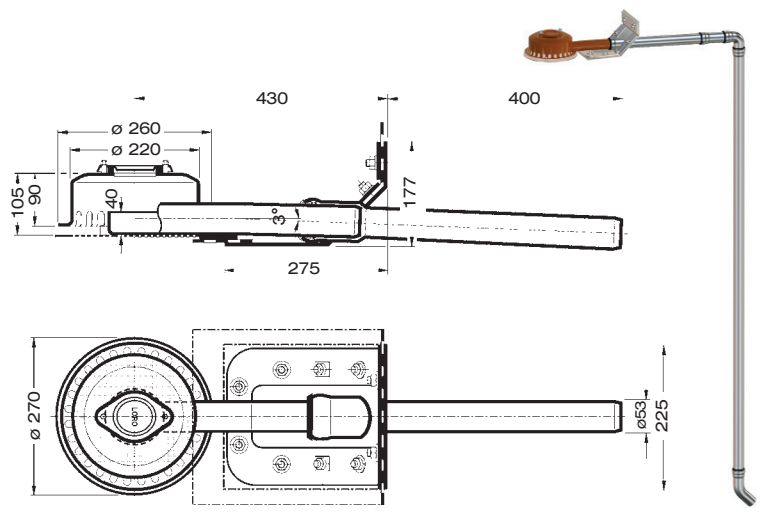

LX1326-3X

Drain Art.-No. 01349.050X

bonding flange 45°
for bituminous roofing sheets
Weir height 40 mm

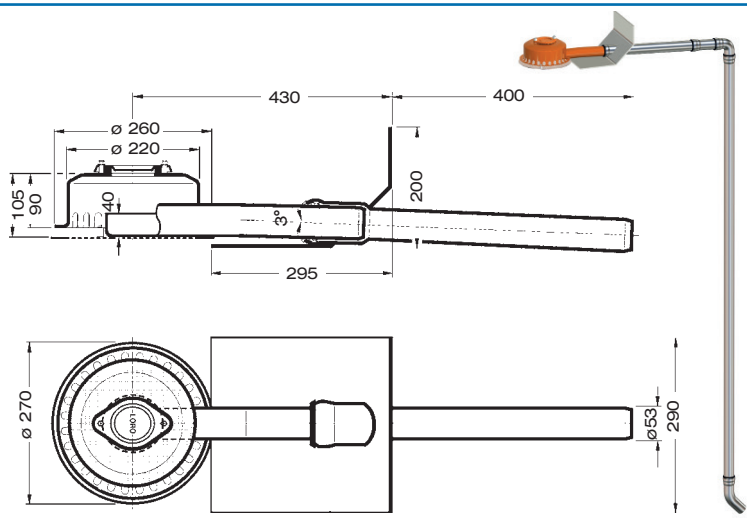

Please note:

For drainage systems with siphonic flow it is vital that only LORO-X pipes and fittings in the combination as indicated are used. Mixture or exchange of system parts may result in lower discharge capacities! The height of the downpipe must be a min. 4.2m for the indicated capacity to be obtained. If roof drain and downpipe are fitted by different crews, then do follow the system setup acc. to the LX-data sheet at www.loro-x.com

Heat tracing: Lorowerk recommends to check all drains and pipes with regard to their frost-sensibility. Where necessary, these parts should be upgraded with heat tracing.

Specification sheet LX 1327

Siphonic Parapet drains Series 62 DRAINJET® without roof penetration

Emergency drainage	
Siphonic flow	
Silent Power	
Discharge rate:	8,5 l/sec
Water height:	75 mm
Roof penetration:	0 mm
Diameter:	DN 50
LX-Number:	LX 1327
Weir height:	60 mm
Drain:	not ventilated
Downpipe:	not ventilated
Downpipe height:	min 4,2 m
Drainage:	on floor

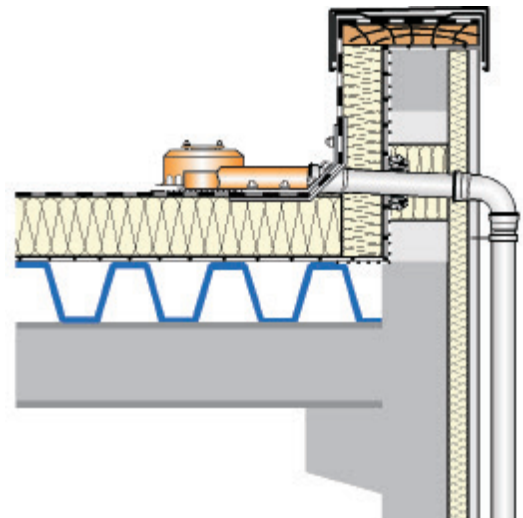

LX 1327 Piece list

- 1 x Art.-No. choose drain on page two!
- 1 x Art.-No. 01401.050X, LORO-X Pipe with one socket
- 1 x Art.-No. 13232.050X, LORO-Sliding flange
- 1 x Art.-No. 00350.050X, LORO-X Bend
- 1 x Art.-No. 01011.050X, LORO-X Pipe with one socket
- 1 x Art.-No. 00320.050X, LORO-X Bend

- 4 x Art.-No. 00911.050X, LORO-X Sealing elements
- 2 x Art.-No. 00973.050X, LORO-X Pipe clamps
- 1 x Art.-No. 00986.000X, LORO-X Lubricant
- 3 x Art.-No. 00806.050X, LORO-X Anchor clips
- 2 x Art.-No. 09603.200X, LORO-X Threaded rods

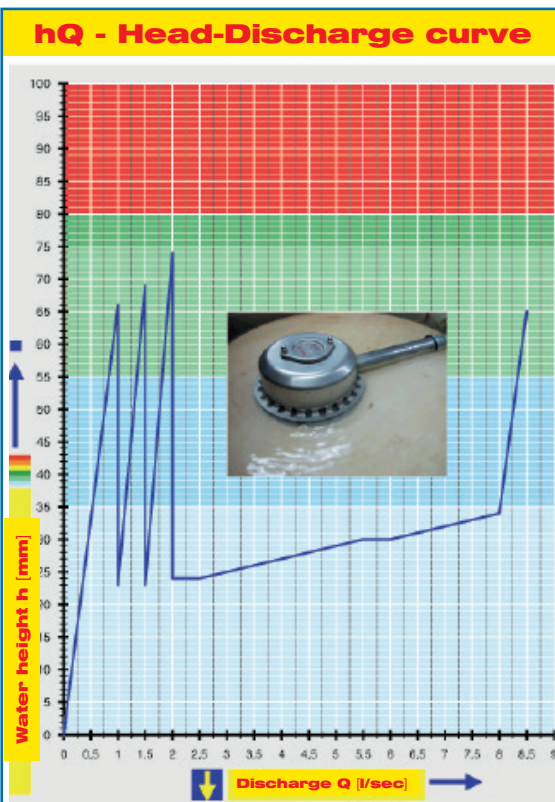

Systempower

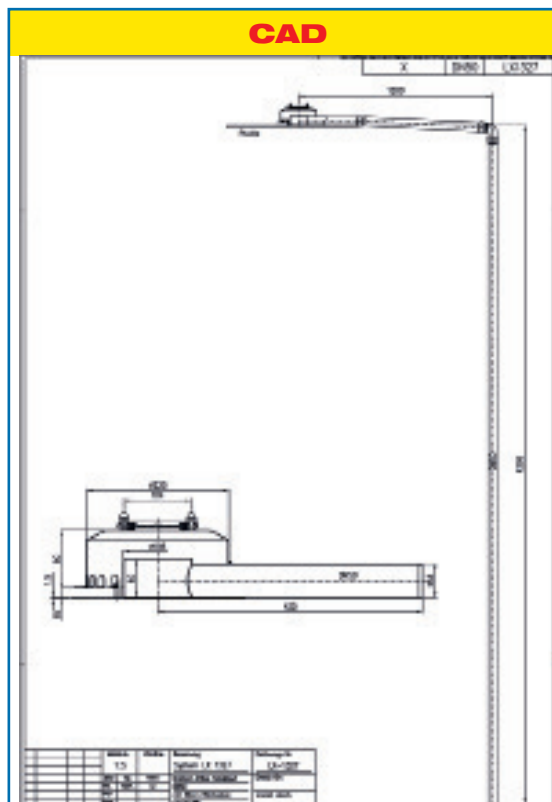

Systemshape

Water height	mm	5	10	15	20	25	30	35	40	45	50	55	60	65	70	75
Discharge	l/sec															8,5
		Silent						Silent Power								

Choose drain for piece list on page one!

LX1327-1X

Drain Art.-No. 01375.050X

clamping flange 90°
for plastic roofing sheets
Weir height 60 mm

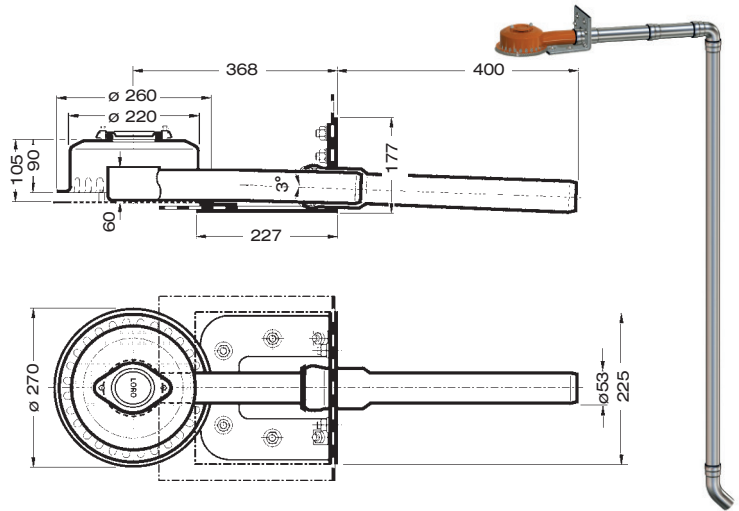

LX1327-2X

Drain Art.-No. 01359.050X

clamping flange 45°
for bituminous roofing sheets
Weir height 60 mm

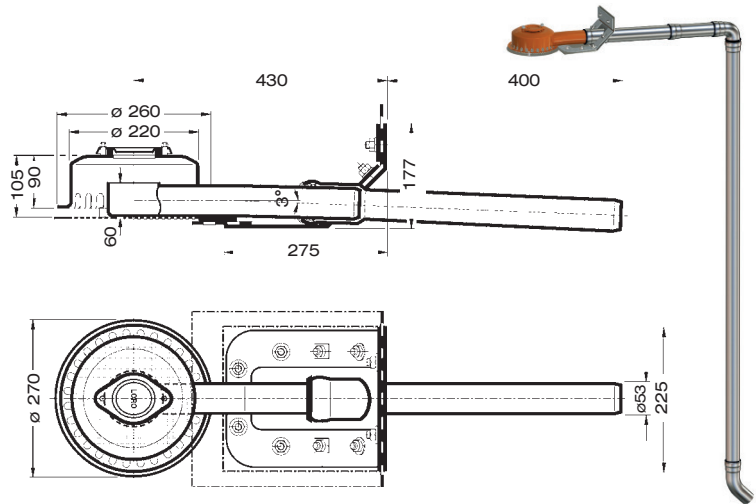

LX1327-3X

Drain Art.-No. 01387.050X

bonding flange 45°
for bituminous roofing sheets
Weir height 60 mm

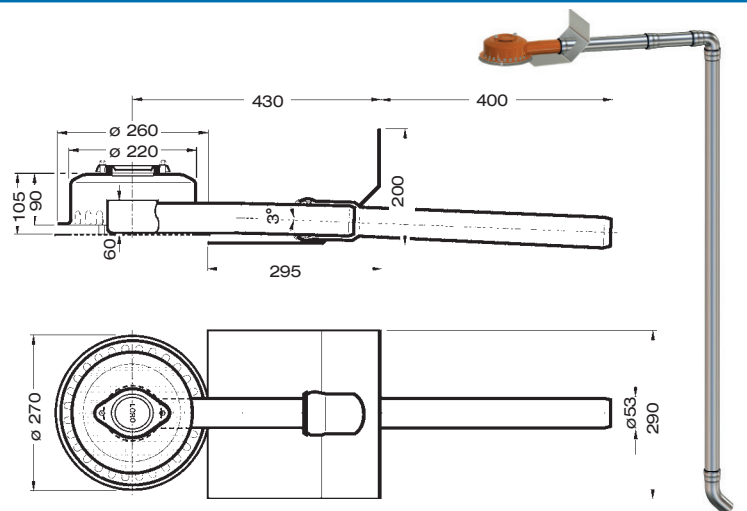

Please note:

For drainage systems with siphonic flow it is vital that only LORO-X pipes and fittings in the combination as indicated are used. Mixture or exchange of system parts may result in lower discharge capacities! The height of the downpipe must be a min. 4.2m for the indicated capacity to be obtained. If roof drain and downpipe are fitted by different crews, then do follow the system setup acc. to the LX-data sheet at www.loro-x.com

Heat tracing: Lorowerk recommends to check all drains and pipes with regard to their frost-sensibility. Where necessary, these parts should be upgraded with heat tracing.

Choose drain for piece list on page one!

LX637-1X

Drain Art.-No. 01358.070X

clamping flange 90°
for plastic roofing sheets

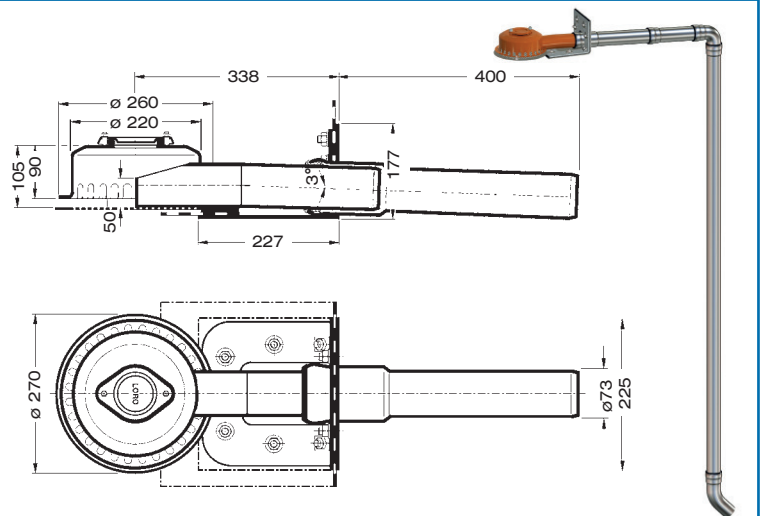

LX637-2X

Drain Art.-No. 01356.070X

clamping flange 45°
for bituminous roofing sheets

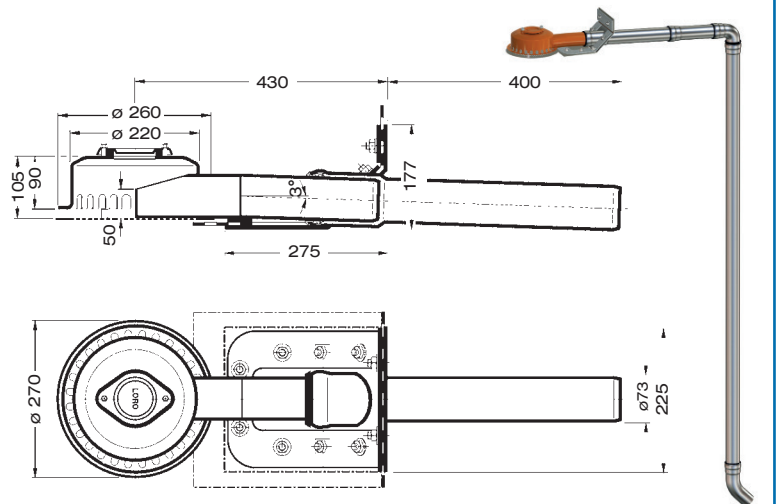

LX637-3X

Drain Art.-No. 01349.070X

bonding flange 45°
for bituminous roofing sheets

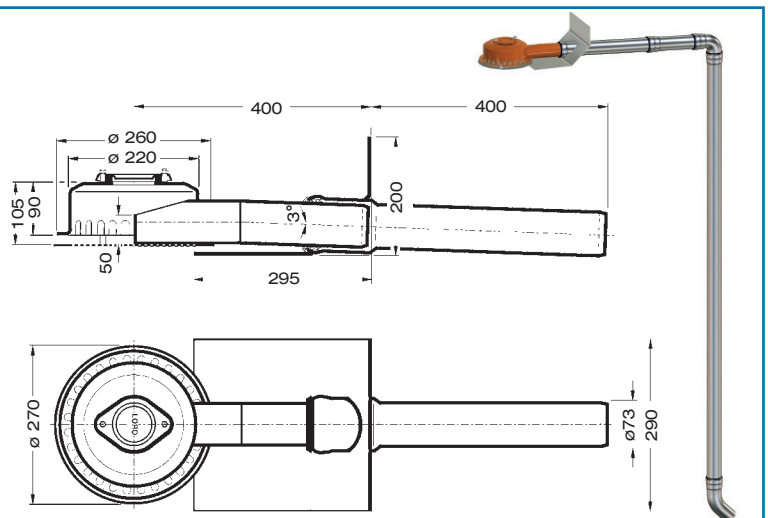

Please note:

For drainage systems with siphonic flow it is vital that only LORO-X pipes and fittings in the combination as indicated are used. Mixture or exchange of system parts may result in lower discharge capacities! The height of the downpipe must be a min. 4.2m for the indicated capacity to be obtained. If roof drain and downpipe are fitted by different crews, then do follow the system setup acc. to the LX-data sheet at www.loro-x.com

Heat tracing: Lorowerk recommends to check all drains and pipes with regard to their frost-sensibility. Where necessary, these parts should be upgraded with heat tracing.

Specification sheet LX 1584

Parapet drainage system Series 62 DRAINLET® without roof penetration

Emergency drainage	
Gravity flow	
Silent	
Discharge rate:	1,0 l/sec
Water height:	75 mm
Roof penetration:	0 mm
Diameter:	DN 50
LX-Number:	LX 1584
Weir height:	40 mm
Drain:	ventilated
Downpipe:	ventilated
Downpipe height:	-
Drainage:	on floor

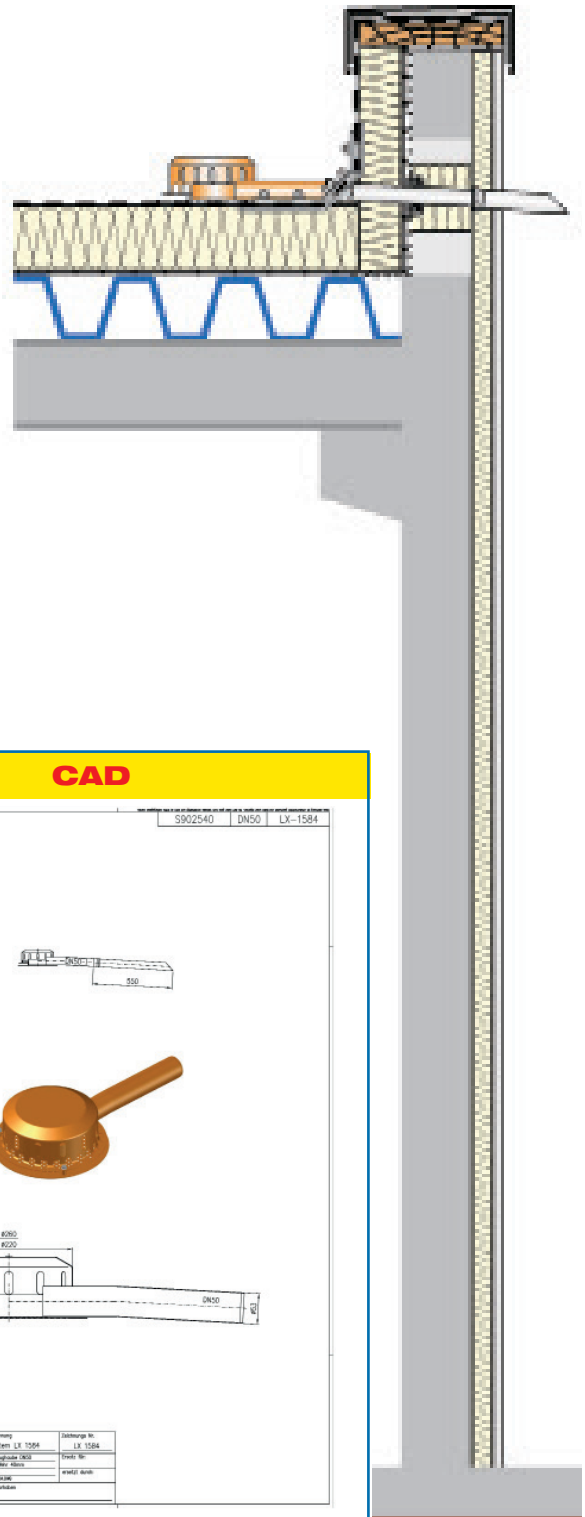

LX 1584 Piece list

- 1 x Art.-No. choose drain on page two!
- 1 x Art.-No. 01401.050X, LORO-X Pipe with one socket
- 1 x Art.-No. 13232.050X, LORO-X Sliding flange
- 1 x Art.-No. 00911.050X, LORO-X Sealing element
- 1 x Art.-No. 00986.000X, LORO-X Lubricant

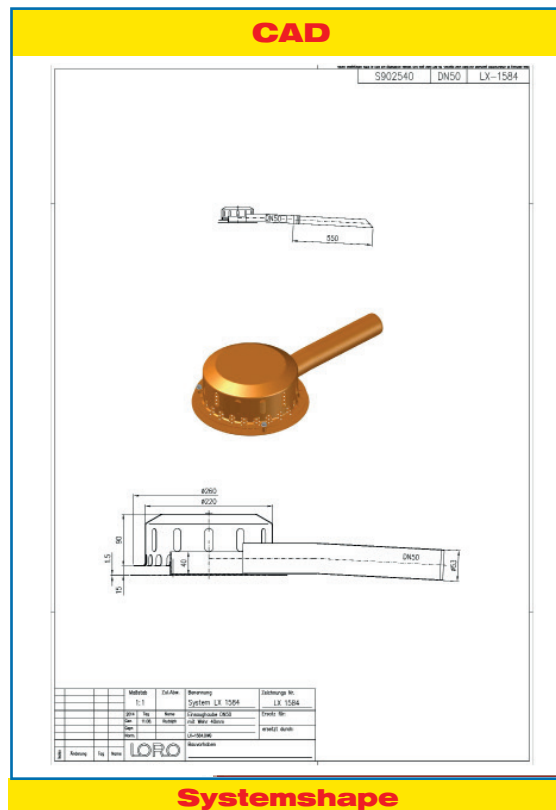
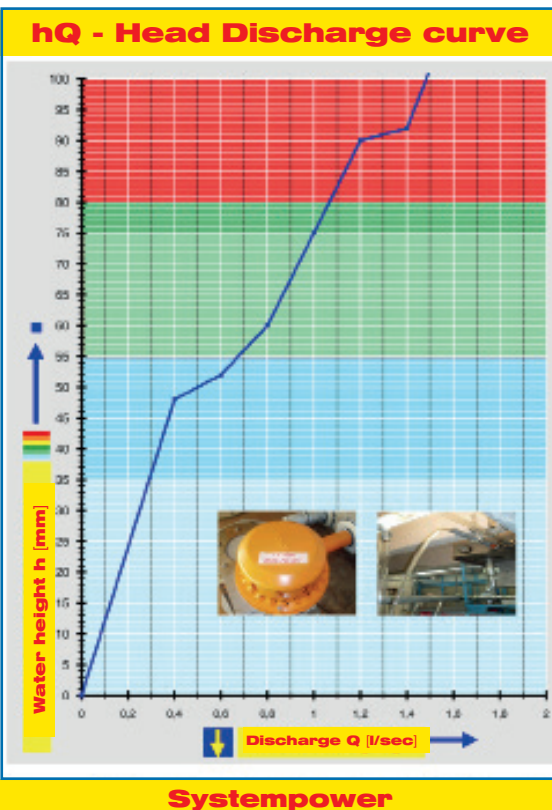

Water height	mm	20	25	30	35	40	45	50	55	60	65	70	75	80	85	90	95	100
Discharge	l/sec	-	-	-	-	-	-	0,5	0,7	0,8	0,9	0,9	1,0	1,1	1,1	1,2	1,4	1,5
Silent																		

Choose drain for piece list on page one!

DN 50

LX1584-1X

Drain Art.-No. 01341.050X

clamping flange 90°
for plastic roofing sheets
Weir height 40 mm

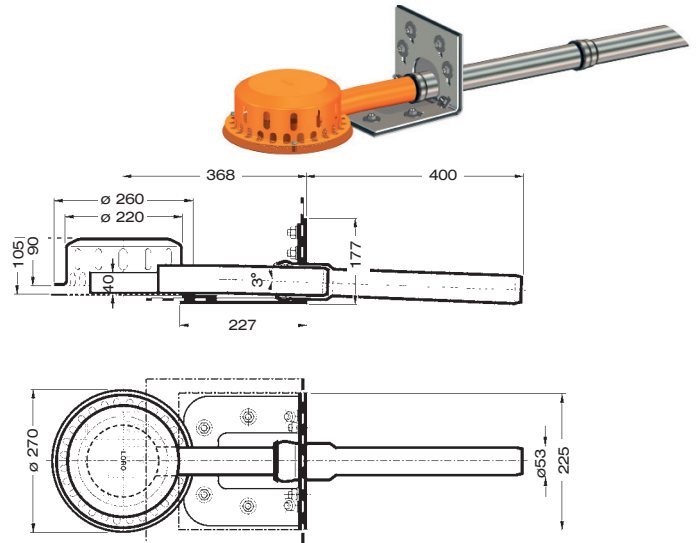

LX1584-2X

Drain Art.-No. 01355.050X

clamping flange 45°
for bituminous roofing sheets
Weir height 40 mm

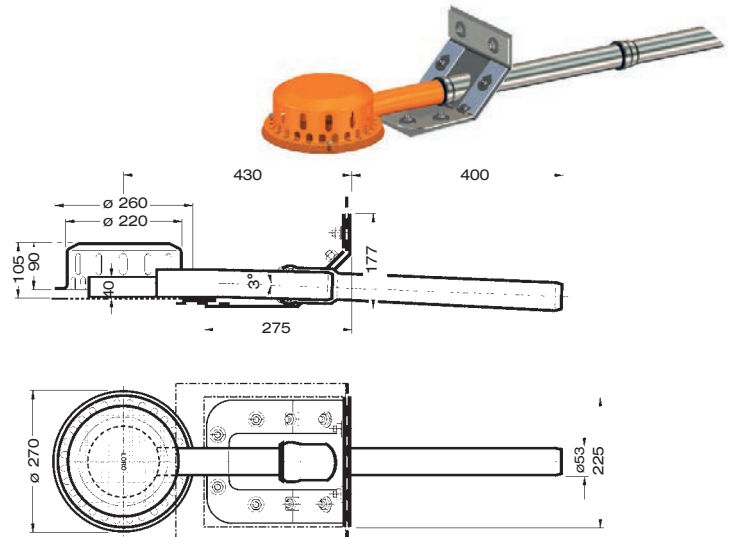

LX1584-3X

Drain Art.-No. 01397.050X

bonding flange 45°
for bituminous roofing sheets
Weir height 40 mm

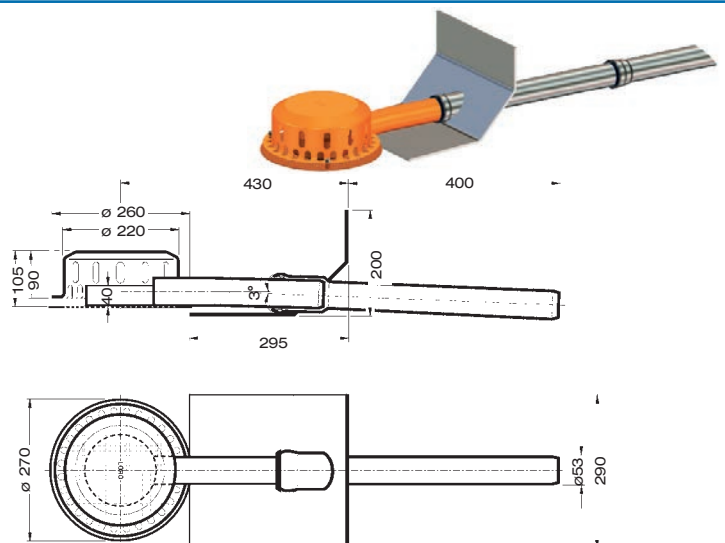

Heat tracing: Lorowerk recommends to check all drains and pipes with regard to their frost-sensibility. Where necessary, these parts should be upgraded with heat tracing.

Choose drain for piece list on page one!

DN 50

LX1585-1X

Drain Art.-No. 01344.050X

clamping flange 90°
for plastic roofing sheets
Weir height 60 mm

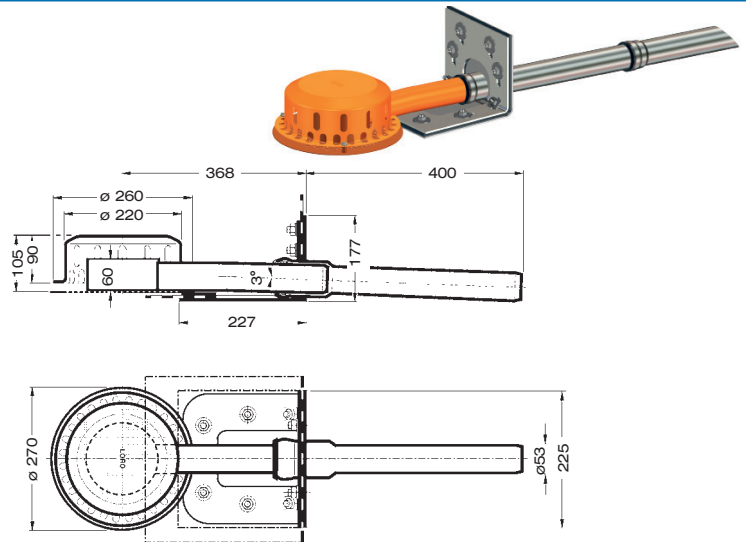

LX1585-2X

Drain Art.-No. 01357.050X

clamping flange 45°
for bituminous roofing sheets
Weir height 60 mm

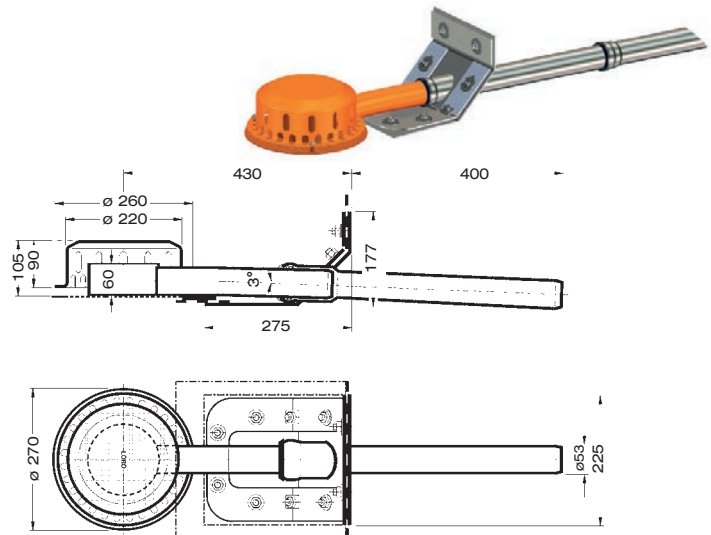

LX1585-3X

Drain Art.-No. 01398.050X

bonding flange 45°
for bituminous roofing sheets
Weir height 60 mm

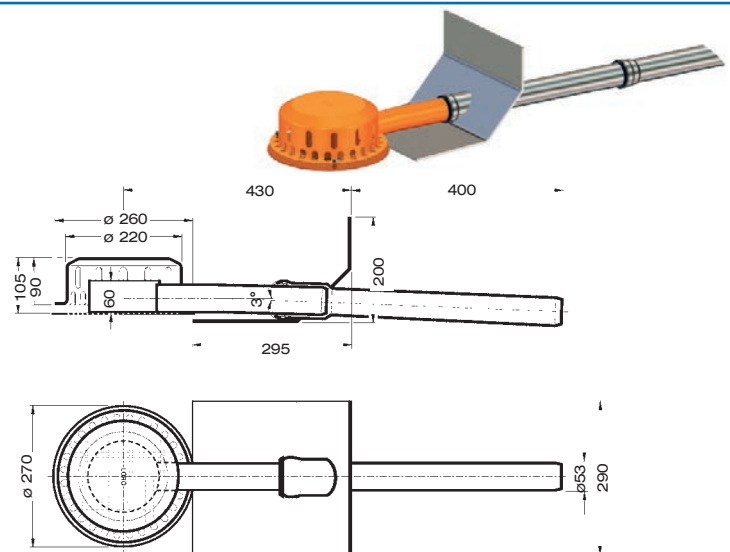

Heat tracing: Lorowerk recommends to check all drains and pipes with regard to their frost-sensibility. Where necessary, these parts should be upgraded with heat tracing.

Specification sheet LX 1607
**Parapet drainage system
Series 62 DRAINLET®
without roof penetration**
Emergency drainage
Gravity flow
Silent

Discharge rate:	1,4 l/sec
Water height:	75 mm
Roof penetration:	0 mm
Diameter:	DN 70
LX-Number:	LX 1607
Weir height:	40 mm
Drain:	ventilated
Downpipe:	ventilated
Downpipe height:	-
Drainage:	on floor

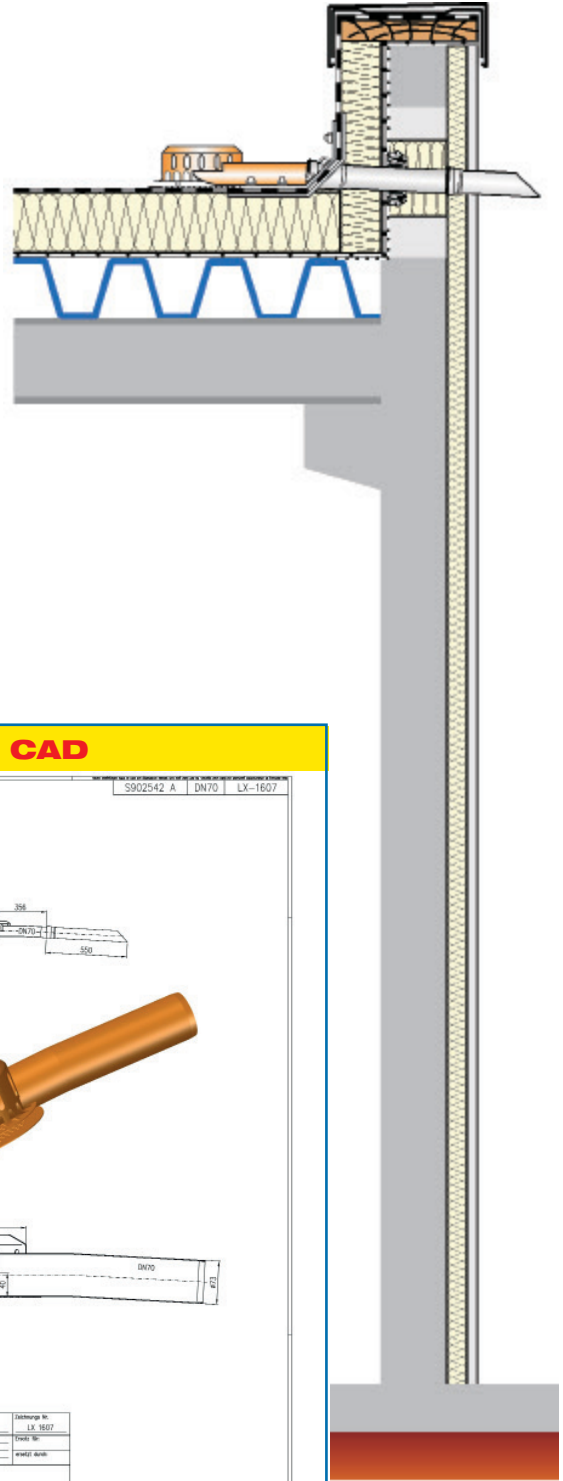
LX 1607 Piece list

- 1 x Art.-No. choose drain on page two!
- 1 x Art.-No. 01401.070X, LORO-X Pipe with one socket
- 1 x Art.-No. 13235.070X, LORO-X Sliding flange
- 1 x Art.-No. 00911.070X, LORO-X Sealing element
- 1 x Art.-No. 00986.000X, LORO-X Lubricant

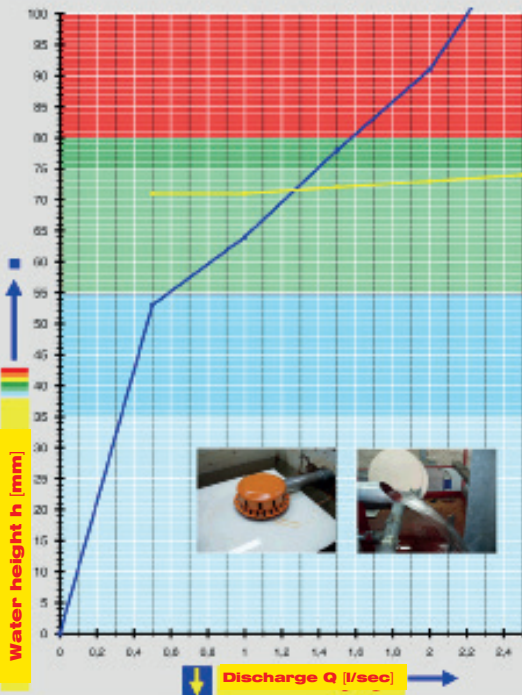
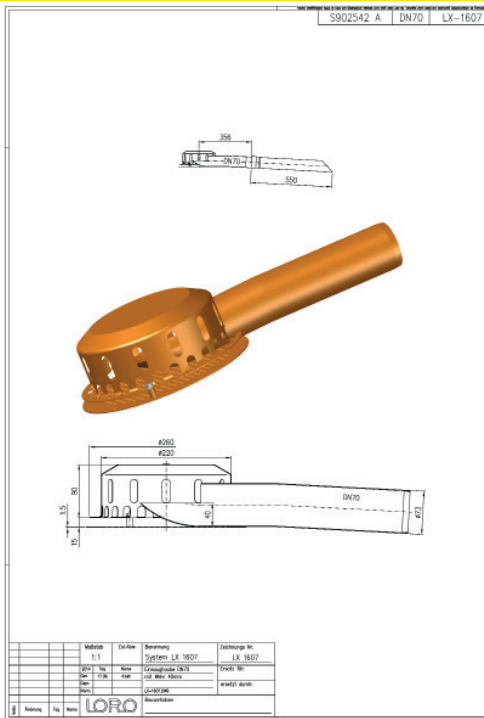
hQ - Head-Discharge curve

Systempower
CAD

Systemshape

Water height	mm	20	25	30	35	40	45	50	55	60	65	70	75	80	85	90	95	100
Discharge	l/sec	-	-	-	-	-	-	-	0,5	0,7	1,0	1,2	1,4	1,6	1,8	2,0	2,1	2,2
Silent																		

Choose drain for piece list on page one!

DN 70

LX1607-1X

Drain Art.-No. 01341.070X

clamping flange 90°
for plastic roofing sheets
Weir height 40 mm

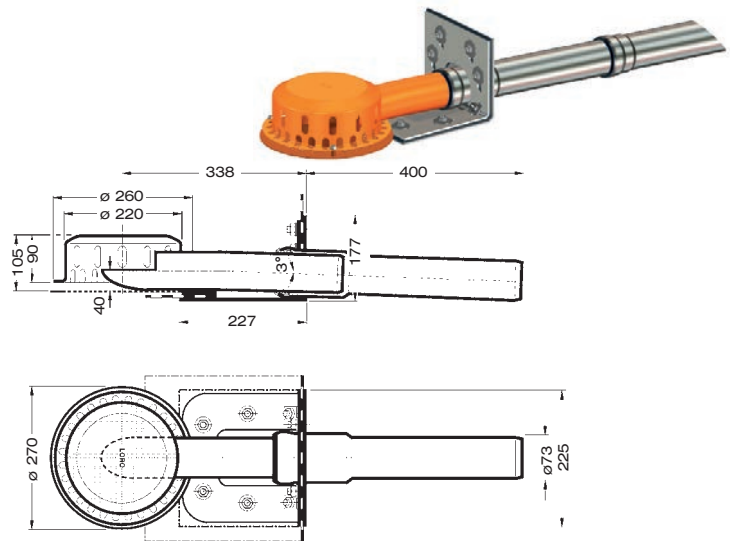

LX1607-2X

Drain Art.-No. 01355.070X

clamping flange 45°
for bituminous roofing sheets
Weir height 40 mm

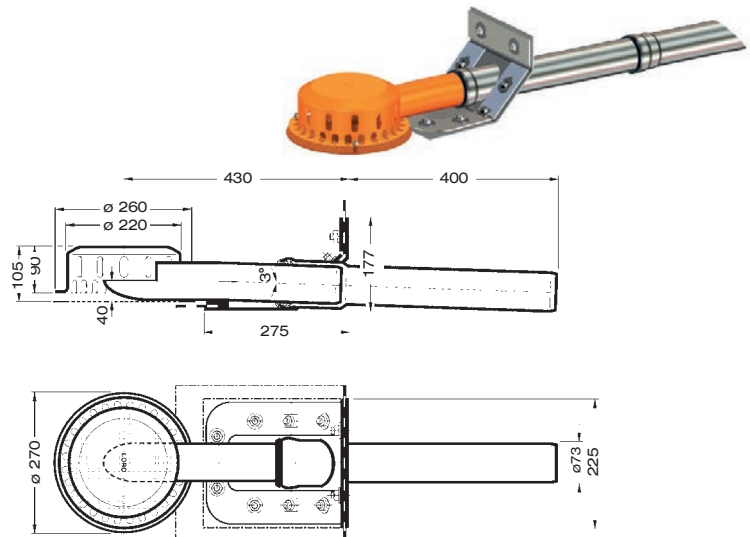

LX1607-3X

Drain Art.-No. 01397.070X

bonding flange 45°
for bituminous roofing sheets
Weir height 40 mm

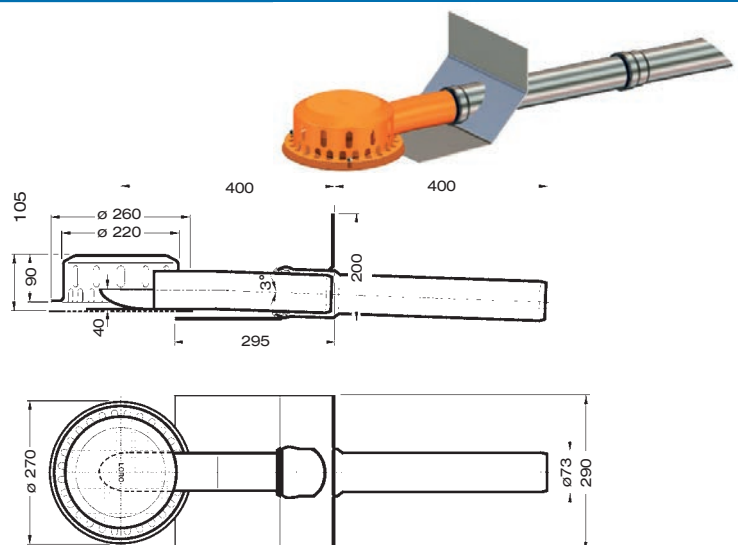

Heat tracing: Lorowerk recommends to check all drains and pipes with regard to their frost-sensibility. Where necessary, these parts should be upgraded with heat tracing.

Choose drain for piece list on page one!

DN 70

LX1587-1X

Drain Art.-No. 1344.070X

clamping flange 90°
for plastic roofing sheets
Weir height 60 mm

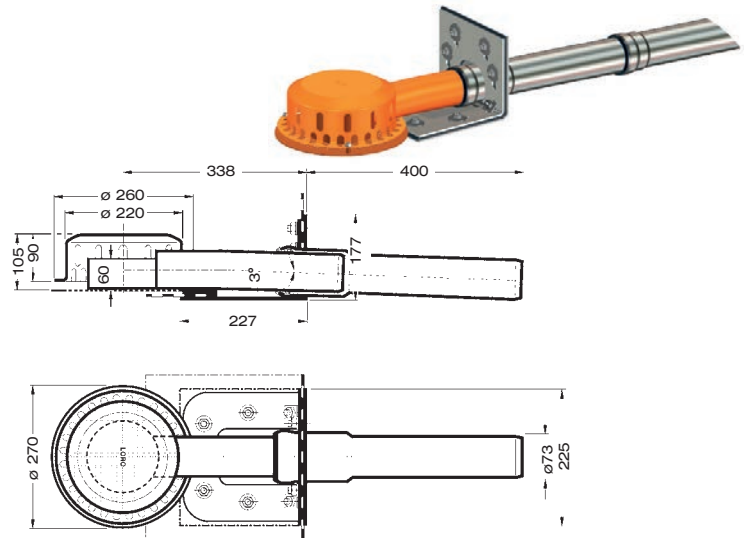

LX1587-2X

Drain Art.-No. 01357.070X

clamping flange 45°
for bituminous roofing sheets
Weir height 60 mm

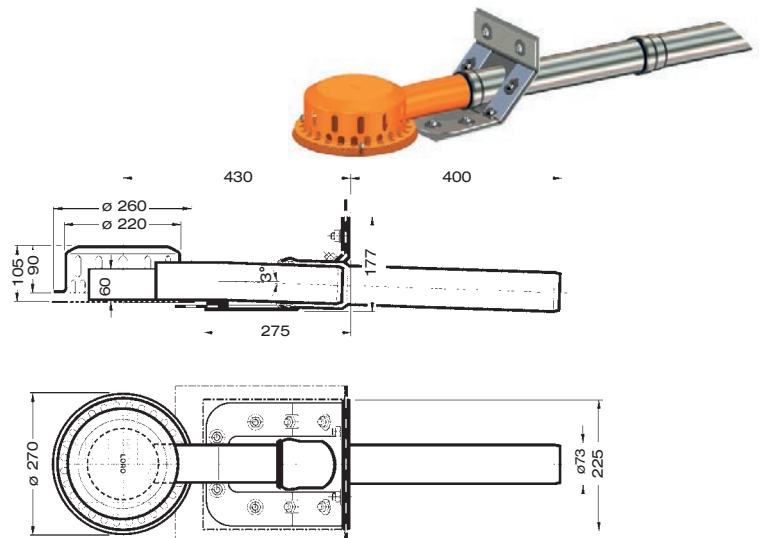

LX1587-3X

Drain Art.-No. 01398.070X

bonding flange 45°
for bituminous roofing sheets
Weir height 60 mm

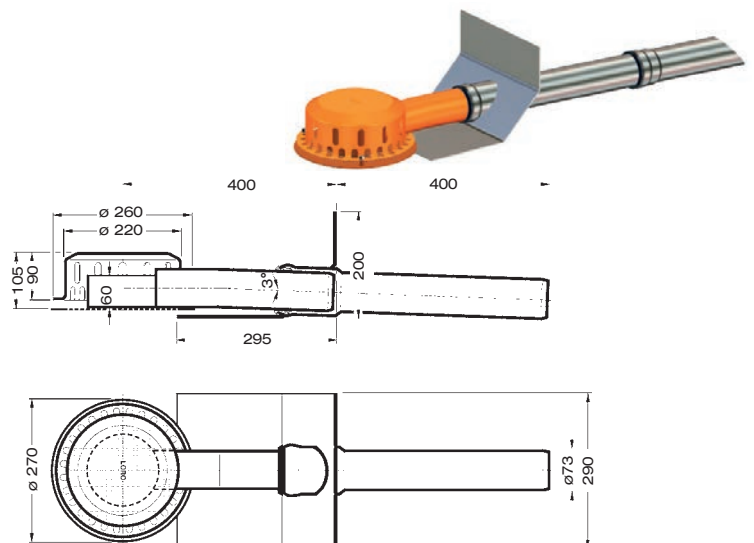

Heat tracing: Lorowerk recommends to check all drains and pipes with regard to their frost-sensibility. Where necessary, these parts should be upgraded with heat tracing.

Calculation of intensity of rainfall

1. Calculation

LORO-X Online Calculation (for Flat roof-Drainage)

1. Calculate the amount of water that has to be drained
2. Choose a LORO-X Scupper-Roof-Drainagesystem from the suggestions based on the calculation
3. Generate a tender for the System from the Drain to the Standpipe including LX-Data sheets

Please insert the Data of the Roof-Surface of your building

Name/Place of building:

Your Name:

Your Email:

Roofage in m²: m² (mandatory field)

Roof type (C):

Choose city:

Normal-Rainfall: (5,5) in Liter/Second/10.000m²

Maximum-Rainfall: (5,100) in Liter/Second/10.000m²

*Dachgerichte muss Wasserfluss zu den Abflüssen gewährleisten
- Fälligkeit bei Druckströmung mindestens 4 Meter
- Freier Auslauf der Rohrunterstützung muss gegeben sein*

Selecting the right ready-made system

2. Configurator

LORO-X Online Configurator

Configure your Roof Drainage System according to the needs of your building.
By choosing a character, the range of alternatives will decrease to the still possible only.

Please make the Online-Calculation!
406 available Systems please make more choices

Way of drainage: Pipes outside (Scupper), Pipes inside, Dach-waagerechter Abgang

Type of drainage: Main-Drainage, Emergency-Drainage, Main-Emergency-Combi

Type of flow: Gravity-flow, Siphonic-flow

Pipe diameter: DN 40, DN 45

Flange type/roof surface: (Scupper) Plastic 90° clamping flange, (Scupper) bituminous 45° clamping flange, (Scupper) bituminous 45° glue flange, (Scupper) Plastic/bituminous

Maximal roof penetration (for scuppers): Maximal 106mm

Foto	LX-Number and short description	Number of Systems depending on Online-Calculation
	LX466-2X 45° clamping flange Not/Emergency: 17.6 1/4 DN 70.	<input type="checkbox"/> x Choose System and show Systemdata in Productdatabase
	LX466-1X 90° clamping flange Not/Emergency: 17.6 1/4 DN 70.	<input type="checkbox"/> x Choose System and show Systemdata in Productdatabase
	LX466-4X clamping flange without lip Not/Emergency: 17.6 1/4 DN 70.	<input type="checkbox"/> x Choose System and show Systemdata in Productdatabase
	LX500-2X 45° clamping flange Not/Emergency: 8.6 1/4 DN 50.	<input type="checkbox"/> x Choose System and show Systemdata in Productdatabase

www.loro-x.com -> Service -> Calculation



www.loro-x.com -> Service -> Configurator



You need three measurements to calculate the necessary discharge rate:

- Roof area in square metres
- Roof structure
- Local intensity of rainfall

The result of the online calculation is the required discharge rate in litres per second. The calculated performance is transferred to the online configurator.

With the LORO-X online configurator you can select the right LORO-X roof drainage system. The following features are taken into account:

- Drainage route (parapet or roof)
- Type of drainage (main or emergency)
- Type of flow (gravity or siphonic)
- Nominal diameter of the pipework system (DN)
- Connection to sealing sheet (bitumen or PVC)
- Penetration depth in the thermal insulation

After successful configuration you will see a list of usable LX systems "below" the configurator.

If you carried out online calculation beforehand the software automatically, determines the necessary qty. of available LX systems.

The selected LX system along with the qty. is then transmitted to the LORO-X product database.

Download specification

Produce quote request and offer

3. Product database



4. Quote request

Search in LORO-X Produkt-database

Examples:
 „LX765“ for LX-System
 „13766.CCXX“ for Art.Nr.
 „Drain“ for Keyword

For every LORO-X Article
 - Pictures
 - 2D and 3D CAD Documents as .dwg
 - dimensioned drawing as PDF

For every LX-System
 - 2D and 3D Systems as .dwg
 - LX Datasheets as PDF

LX-Complete Systems

Complete System LX637
 With 45° clamping flange

Recommended System-specification text:
 LORO-X Siphonic Scupper Roof-Drainage System without penetration of the roof including Siphonic Scupper Emergency Drain with 45 Degree clamping flange, horizontal wrapage, bend with short radius, safety clamps, sliding flange, sealing elements and lubricant, ready to install. This siphonic roof drainage system has to be completed with LORO-X downpipes to get the mentioned discharge rate. Please ask your local dealer or LORO-contact person. Proof of performance can be downloaded as data-sheet LX637 on www.loro-x.com with 14.5% at 75mm water height, DN70

System containing of these articles:
 1 x 01356.070X - LORO-X DRAINJET SCUPPER EMERGENCY DRAIN, SIPHONIC FLOW, SERIES 62, WITHOUT ROOF PENETRATION, WITH CLAMPING FLANGE FOR
 1 x 01401.070X - LORO-X PIPE WITH 1 SOCKET 250 MM DN 70
 1 x 00350.070X - LORO-X SHORT RADIUS BEND 87 DEGREE DN 70
 1 x 01011.070X - LORO-X PIPE WITH 1 SOCKET 4000 MM DN 70
 1 x 00320.070X - LORO-X BEND 45 DEGREE DN 70
 4 x 00911.070X - LORO-X SEALING ELEMENT 58R DN 70
 2 x 00973.070X - LORO-X PIPE CLIP WITH CONNECTING THREAD M 8 DN 70
 1 x 00986.000X - LORO-X LUBRICANT 250 G TUBE
 1 x 13235.070X - LORO-X SLIDING FLANGE WITH PRE-INSTALLED CONNECTION SLEEVE FOR VAPOR BARRIER WITH

Multimedia

LX637-2X
 45° clamping flange

[Specification sheet LX637](#)
[System CAD 2D](#)
[System CAD 3D](#)
[Dimensional Drawing](#)
[LX-System](#)
[Add to shopping-basket](#)

LORO-X Online Specification

Insert the article numbers directly, or add by using the product-database.

LV-Identificationcode
 LV-password

[Start new/empty specification](#)

Project data:

Name and place of building
 LORO Offernumber
 Contactperson (+ Tel. or Email)

Important: Care for correct spelling of the article-numbers: '00100.000X' including Zero-Numbers in the beginning! Mistyping of article-numbers results in a wrong specification! LORO is not responsible for wrong specifications. To remove articles from the specification, please type 0 as amount.

Pos.	Amount	LORO-X Article-number	LORO-X short description
1	1	01356.070X	LORO-X DRAINJET SCUPPER EMERGENCY DRAIN, SIPHONIC FLOW, SERIES 62, WITHOUT ROOF PENETRATION, WITH CLAMPING FLANGE FOR
2	1	01401.070X	LORO-X PIPE WITH 1 SOCKET 250 MM DN 70
3	1	00350.070X	LORO-X SHORT RADIUS BEND 87 DEGREE DN 70
4	1	01011.070X	LORO-X PIPE WITH 1 SOCKET 4000 MM DN 70
5	1	00320.070X	LORO-X BEND 45 DEGREE DN 70
6	4	00911.070X	LORO-X SEALING ELEMENT 58R DN 70

[Save/show shopping-basket](#)

www.loro-x.com -> Service -> Product database

www.loro-x.com -> Service -> Specification



LX datasheet as .pdf

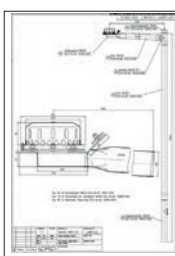

2D-CAD .pdf and .dwg



3D CAD as .dwg

For each individual item (approximately 2500 items) and for each complete LX datasheet you will find in the LORO-X online product database:

- LX datasheet
- 2D and 3D drawings as CAD files (.dwg)
- 2D drawing as PDF document
- Tender texts
- Item number, photograph, weight, nominal diameter, EAN code, customs tariff number
- Installation instructions and application examples

Pos.	Amount	Article	Description	Single Export-Price	Fold	Export-Price
1	1x	01356.070X	LORO-X Siphonic-Scupper-Drain without roof penetration for LORO-X Scupper-Roof-Drainage-Systems with Siphonic-Flow, series 62, for Emergency-Drainage with clamping flange and 45 degree raised edge for bituminous roofing-sheets, made of stainless steel, DN 70. The mentioned discharge-rate for siphonic flow with 14.5l/sec at 75mm water-height will only be reached with the LORO-X Systemshape with LORO-X steel-pipes given in data-sheet LX637. Please take care of the storage-height of min. 4.2m and the given redirection at the parapet. WS: 9 ABM1: 70	500,40€		500,40 €
2	1x	01401.070X	LORO-X Steel-Pipe according to DIN EN 1123, with push-fit-socket (1 socket), made of steel, hot-dip galvanised, internal coating based on a two-components epoxy combination, Color: Red-brown, 250 mm, DN 70 ABM1: 70	13,20€		13,20 €
3	1x	00350.070X	LORO-X Bend with small radius, according to DIN EN 1123, with push-fit-socket, made of steel, hot-dip galvanised, internal coating based on a two-components epoxy combination, Color: Red-brown, 87 degree, DN 70 ABM1: 70	24,70€		24,70 €
4	1x	01011.070X	LORO-X Steel-Pipe according to DIN EN 1123, with push-fit-socket (1 socket), made of steel, hot-dip galvanised, internal coating based on a two-components epoxy combination, Color: Red-brown, 4000 mm, DN 70 ABM1: 70	138,80€		138,80 €
5	1x	00320.070X	LORO-X Bend according to DIN EN 1123, with push-fit-socket, made of steel, hot-dip galvanised, internal coating based on a two-components epoxy combination on plastic-basis, Color: Red-brown, 45 degree, DN 70 ABM1: 70	16,90€		16,90 €
6	4x	00911.070X	LORO-X sealing element made of Elastomer, for LORO-X Steel-Pipe push-fit-socket, DN 70 ABM1: 70	2,70€		10,80 €
7	2x	00973.070X	LORO-X Steel-Pipeclamp with connecting thread M 8, made of steel, hot-dip galvanised, without sound-damping, DN 70 ABM1: 70	6,10€		12,20 €
8	1x	00986.000X	LORO-X lubricant 250 Gramm	6,20€		6,20 €
9	1x	13235.070X	LORO-X sliding flange with connecting collar, made of steel, hot-dip galvanised, for vapor seal for bituminous roofing-sheets DN 70	70,60€		70,60 €

The LORO-X online tendering system generates a prepared offer or tender from a list of items. Every newly prepared offer is assigned a unique identification number and password, with which you can open the prepared offer again at any time and continue working on it:

- Screen output (e.g. print as PDF)
- .csv file (import e.g. in Excel)
- .X81 file (GAEB XML)

International representatives
Norway

SHELBY TEKNIKK A/S
Strandgaten 55
N-4371 Egersund
Tel.: +47 51 461 800
ko@shelby.no

Finnland

OY INTERCO AB
Elimäenkatu 12 - 16A
FI-00510 Helsinki
Tel.: +358 9 774 3220
office@interco.fi

Great Britain

Cathelco Ltd t/a
TRANSVAC SYSTEMS
Marlowe House, Unit B
Rudford Industrial Estate
Ford, Arundel
UK-West Sussex BN 18 OBF
Tel.: +44 1903 736 900
sales@transvac-systems.co.uk

Denmark

BAHEKO A/S
Vandmestervej 37
DK-2630 Taastrup
Tel.: +45 43 991 611
baheko@baheko.dk

Netherland/Belgium

LOROMEIJ-GOOR B.V.
Gruttostraat 75
NL-7470 AB Goor
Tel.: +31 547 272 696
info@loromeij.nl

Luxembourg

LOROWERK
K.H.Vahlbrauk GmbH & Co.KG
Ullrich Stichnoth
Offenbacher Str. 24
D-63263 Neu-Isenburg
Tel.: +49 6102 308549
ullrich.stichnoth@lorowerk.de

Poland/Baltic States

KRZYSZTOF PAMULA
Im Spargelfeld 23 A
D-31626 Haßbergen
Tel.: +49 5024 88 78 44
loro@harpyie.pl

Czech Republic

TOPWET s.r.o.
Náměstí Viléma Mrštíka 62
CZ-664 81 Ostrovačice
Tel.: +420 530 507 486
info@topwet.info

Slovak Republic

SLOVINTERNORM s.r.o.
Stare Grunty 130
SK-84104 Bratislava
Tel.: +421 2 555 644 79
info@internorm.sk

Slovenia

SIES napredne resitive d.o.o.
Danijel Voncina
Ulica Lavznik 19
SI-5290 Sempeter pri Gorici
Tel.: +386 5 93 75 152
danijel.voncina@sies.si

Austria

LOROWERK
K.H.Vahlbrauk GmbH & Co.KG
Matthias de Waal
Oskar-Helmer-Str. 22
2540 Bad Vöslau
Mobil: +43 664 413 320 0
matthias.dewaal@lorowerk.de

Switzerland

WISAN-TECHNIK AG
Gubelstr. 19
CH-6300 Zug
Tel.: +41 41 711 50 35
wisan@bluewin.ch

Romania

SEVA-GROUP SRL
Strada Vulturului 15
RO-500264 Brasov
Tel.: +40 268 312 826
info@sevagroup.ro

Portugal

Shipbuilding only:
MARINE-TECHNIK-SERVICE
Ausblick 22
D-42113 Wuppertal
Tel.: +49 202 720 002
info@angelmeier.com

Spain

GEPRO PLUS 2006 s.l.
Edificio E10, Nave 7
E-28880 Meco (Madrid)
Tel.: +34 918.307.245
geproplus@geproplus.com

Italy/Croatia

Fabio Marabini
consulente tecniche
Via dell'Aprica 6
I-24125 Bergamo
Tel.: +39 035 210 081
fabio@marabini.net

Bulgaria

Shipbuilding only:
MORGAN Ltd.
29 A, Michael Koloni Str.
BG-9000 Varna
Tel.: +359 52/631 222, 615 709
office@morganbg.com

Greece

JGP HELLAS Ltd.
Marine & Industrial Equipment
6,Bouboulinas Street
GR-18535 Piräus
Tel.: +30 210 422 37 48
info@jgp.gr

Russia

ООО «Акритек Плюс»
Mr. Eduard Zhitnik
109451, г. Москва, ул.Братиславская, д.14
тел./факс : +7-495-710-23-46
тел.+7-495-679-48-07; 8-985-762-94-01 моб.Эдуарда
почта: acrytec@gmail.com

China

PROCO INTERNATIONAL Ltd.
Unit 1913,19/F
BEA Tower,
Millenium City 5,
418 Kwun Tong Road,
Kwun Tong, Kowloon
Hong Kong
Tel.: +852 18 08 08 6
customerservice@proco.com.hk

Singapore/Malaysia

Marketing M&E 2000 pte ltd.
Herr Edmund Kan
50 Ubi Ave 3# 02-09
Singapore 408866
Tel.: +65 6285 9296
edmund_sales@mme2000.com.sg

Vietnam

Proco International Company Limited Vietnam
Representative Office
Room 805, 8/F., Thang Long Building,
105 Lang Ha, Dong Da,
Hanoi, Vietnam
Tel : 84-43-5625288, 84-43-5625289
customerservice@proco.com.hk

United States

Building Construction:
LORO-JOSAM
525 West Hwy. 20
Michigan City, IN 46360
Tel.: +1 219 872 5533
loro@josam.com
Shipbuilding only:
GLOBAL SUPPLY COMPANY
590 Ansin Blvd.
Halledale, IL 33009
Tel.: +1 954 454 1234
charles@gscusa.com

Germany

LOROWERK
K.H. Vahlbrauk GmbH&Co.KG
Kriegerweg 1
37581 Bad Gandersheim
Tel.: +49 53 82 710
infocenter@lorowerk.de
Peter Kuck
Export director
Schlipsheimer Str. 119
86356 Neusaess
Tel.: +49 821.248 90 59
peter.kuck@lorowerk.de